



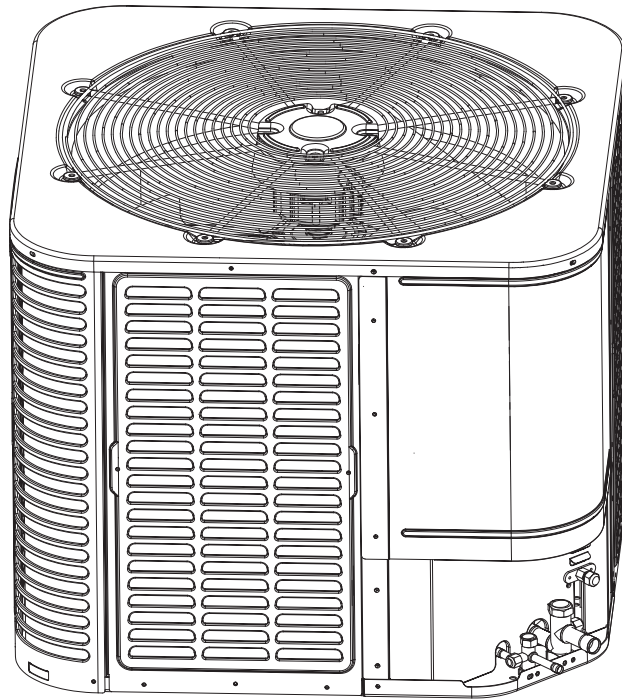
# INSTALLATION INSTRUCTIONS

## Split System Heat Pump & Air Conditioner

Model Size:

Fixed Speed 1.5&2&2.5&3&3.5&4&5 Tons

### R454B




# CONTENTS

1. Symbol and Key to Safety Instructions.....	01
2. Considerations of Unit Location .....	09
3. Unit Installation Preparation .....	15
4. Unit Settings .....	16
5. Precautions for Refrigerant Pipeline.....	17
6. Refrigerant Pipeline Routing .....	19
7. Refrigerant Line Brazing.....	21
8. Refrigerant Line Leakage Inspection.....	23
9. Vacuuming.....	24
10. Service Valve.....	25
11. Electrical-Low Voltage .....	26
12. Electrical-High Voltage .....	29
13. Start.....	30
14. System Refrigerant Charging Method .....	31
15. System Operation and Troubleshooting .....	34
16. Wiring Diagram.....	43
17. Cleaning and Maintenance.....	44

# 1. Symbol and Key to Safety Instructions


## 1.1 Symbol Keywords

	<b>WARNING</b>	The warnings in this document are identified by warning triangles printed on a black background. The key words at the beginning of the warning indicate the type and severity of the next risk if no measures are taken to prevent it.
---	----------------	--

The following keywords are defined and used in this document:


<input type="checkbox"/>	<b>Danger</b>	Indicates a hazardous situation, which, if not avoided, will lead to death or serious injury.
<input type="checkbox"/>	<b>Warning</b>	Indicates a hazardous situation, which, if not avoided, may lead to death or serious injury.
<input type="checkbox"/>	<b>Caution</b>	Indicates a hazardous situation, which, if not avoided, may cause mild to moderate injury.
<input type="checkbox"/>	<b>Note</b>	Used to deal with behaviors unrelated to personal injury.


### Important information

	This symbol represents important information that is not dangerous to people or property.
---	---

## 1.2 Safety

Please Read Before Continuing.

	<b>WARNING</b>	<input type="checkbox"/> Failure to observe this warning may result in property damage, serious personal injury or death.
		<input type="checkbox"/> Before touching the electrical components, wait for 3 minutes after disconnecting the power supply.

	<b>NOTICE</b>	<input type="checkbox"/> This document is the property of the customer and is kept by this unit. When you are finished, please return to the service information package.
		<input type="checkbox"/> These instructions do not cover all changes in the system, nor do they provide all unexpected situations that may be encountered during installation.
		<input type="checkbox"/> If you need more information, or there are special problems that are not sufficient for the buyer, you should consult your installation dealer or local dealer.



Some benefits of installing an approved indoor and outdoor split system are maximum efficiency, best performance and best overall system reliability.



This document contains wiring diagram and maintenance information. This is the customer's property and belongs to this unit. When you are finished, please return to the service information package.

### Warning:

- The unit must be installed by qualified personnel with a capability certificated for handling refrigerant fluids. Refer to regulation and laws in use on installation location.
- Installation, service, maintenance and repair of this unit must be performed by a certified technician.
- Servicing shall be performed only as recommended by the manufacturer.
- Product uninstallation and recycling must be performed by a certified technician.
- The appliances is designed to be operated in outdoor area. If have to be installed indoor, the appliance shall be stored in a room without continuously operating open flames (for example an operating gas appliance) and ignition sources (for example an operating electric heater).
- This appliance is not intended for use by persons (including children) with reduced physical, sensory or mental capabilities, or lack of experience and knowledge, unless they have been given supervision or instruction concerning use of the appliance by a person responsible for their safety.
- The appliance shall be installed in accordance with national wiring regulations.
- Children should be supervised to ensure that they do not play with the appliance.
- Before accessing the connection terminals, all power circuits must be disconnected.
- This information is intended for use by individuals with sufficient electrical and mechanical experience background. Attempting to repair central air conditioning products may result in personal injury and/or property damage.



### Warning: Dangerous voltage

- Failure to observe this warning may result in property damage, serious personal injury or death.
- Can cause injury or death. Disconnect all remote electric power supplies before servicing. Follow proper locking/tagging procedures to ensure that the power supply will not be energized accidentally.



### Warning: Refrigerant oil

- Attempting to repair central air-conditioning products may result in property damage, serious personal injury or death. These units use R454B refrigerant. Use only the service equipment approved by R454B. This systems use POE oil, which can easily absorb moisture from the atmosphere. In order to limit this "moisture absorption" effect, the system should be sealed as much as possible. If the system is exposed to the atmosphere for more than 4 hours, the compressor oil must be changed. Do not destroy the vacuum with air, and always replace the filter dryer when you open the system for component replacement.





### Warning: Hot surface

- May cause mild to severe burns. Failure to observe this caution may result in property damage or personal injury. Do not touch the top of the compressor.



### Caution: Contains refrigerant

- Failure to follow the correct procedures will lead to personal illness or injury or serious equipment damage. The system contains high-pressure oil and refrigerant. Before opening the system, recover the refrigerant to release the pressure.



### Note:

- The manufacturer recommends installing only approved matched indoor and outdoor systems. Some of the benefits of installing approved matched indoor and outdoor split systems are maximum efficiency, optimum performance and the best overall system reliability.



### Note: Grounding required

- Failure to check or use the correct maintenance tools may result in equipment damage or personal injury. Reconnect all grounding devices. All parts of this product that can conduct current are grounded. If the grounding wire, screw, strap, clip, nut or washer used to complete the grounding path is removed during maintenance, it must be put back in place and properly fixed.



### Warning: service valve

- Failure to observe this warning will result in release of system pressure, which may result in personal injury and/or property damage. When opening the liquid pipeline service valve, be extra careful. Turn the valve stem counterclockwise until the valve stem touches the bead.



### Warning: Brazing required

- Failure to check the wiring or use the correct maintenance tools may result in equipment damage or personal injury. If using existing refrigerant lines, make sure that all joints are brazed, not soldered.



### Warning: High current leakage

- Failure to observe this warning may result in property damage, serious personal injury or death. Before connecting the power supply, grounding is essential.



### Warning:

- This product may expose you to chemicals including lead and lead components, which are known to cause cancer, birth defects or other reproductive harm in California. For more information, please visit [www.P65Warnings.ca.gov](http://www.P65Warnings.ca.gov).

### Warning:



- Do not use means to accelerate the defrosting process or to clean, other than those recommended by the manufacturer.
- The appliances is designed to be operated in outdoor area. If have to be installed indoor, the appliance shall be stored in a room without continuously operating ignition sources (for example: open flames, an operating gas appliance or an operating electric heater.)
- Do not pierce or burn.
- Be aware that refrigerants may not contain an odour.

	<b>WARNING</b>	This symbol that this appliance used a flammable refrigerant. If the refrigerant is leaked and exposed to an external ignition source, there is a risk of fire.
	<b>CAUTION</b>	This symbol that the operation manual should be read carefully.
	<b>CAUTION</b>	This symbol that a service personnel should be handling this equipment with reference to the installation manual.
	<b>CAUTION</b>	This symbol that information is available such as the operating manual or installation manual.

## 1.3 Instructions for repairing appliances containing R454B

### Warning:



- Do not use means to accelerate the defrosting process or to clean, other than those recommended by the manufacturer.
- The appliance shall be stored in a room without continuously operating ignition sources (for example: open flames, an operating gas appliance or an operating electric heater.)
- Do not pierce or burn.
- Be aware that refrigerants may not contain an odour.

### Qualification of workers

Every working procedure like maintenance, service and repair operations that affects safety means shall only be carried out by competent persons.

Examples for such working procedures are:

- breaking into the refrigerating circuit;
- opening of sealed components;
- opening of ventilated enclosures.

### Checks to the area

Prior to beginning work on systems containing FLAMMABLE REFRIGERANTS, safety checks are necessary to ensure that the risk of ignition is minimised.

### Work procedure

Work shall be undertaken under a controlled procedure so as to minimise the risk of a flammable gas or vapour being present while the work is being performed.

### **General work area**

All maintenance staff and others working in the local area shall be instructed on the nature of work being carried out. Work in confined spaces shall be avoided.

### **Checking for presence of refrigerant**

The area shall be checked with an appropriate refrigerant detector prior to and during work, to ensure the technician is aware of potentially toxic or flammable atmospheres. Ensure that the leak detection equipment being used is suitable for use with all applicable refrigerants, i.e. non-sparking, adequately sealed or intrinsically safe.

### **Presence of fire extinguisher**

If any hot work is to be conducted on the refrigerating equipment or any associated parts, appropriate fire extinguishing equipment shall be available to hand. Have a dry powder or CO<sub>2</sub> fire extinguisher adjacent to the charging area.

### **No ignition sources**

No person carrying out work in relation to a REFRIGERATING SYSTEM which involves exposing any pipe work shall use any sources of ignition in such a manner that it may lead to the risk of fire or explosion. All possible ignition sources, including cigarette smoking, should be kept sufficiently far away from the site of installation, repairing, removing and disposal, during which refrigerant can possibly be released to the surrounding space. Prior to work taking place, the area around the equipment is to be surveyed to make sure that there are no flammable hazards or ignition risks. "No Smoking" signs shall be displayed.

### **Ventilated area**

Ensure that the area is in the open or that it is adequately ventilated before breaking into the system or conducting any hot work. A degree of ventilation shall continue during the period that the work is carried out. The ventilation should safely disperse any released refrigerant and preferably expel it externally into the atmosphere.

### **Checks to the refrigerating equipment**

Where electrical components are being changed, they shall be fit for the purpose and to the correct specification. At all times the manufacturer's maintenance and service guidelines shall be followed. If in doubt, consult the manufacturer's technical department for assistance.

The following checks shall be applied to installations using FLAMMABLE REFRIGERANTS:

- the actual REFRIGERANT CHARGE is in accordance with the room size within which the refrigerant containing parts are installed;
- the ventilation machinery and outlets are operating adequately and are not obstructed;
- if an indirect refrigerating circuit is being used, the secondary circuit shall be checked for the presence of refrigerant
- marking to the equipment continues to be visible and legible. Markings and signs that are illegible shall be corrected;
- refrigerating pipe or components are installed in a position where they are unlikely to be exposed to any substance which may corrode refrigerant containing components, unless the components are constructed of materials which are inherently resistant to being corroded or are suitably protected against being so corroded.

### **Checks to electrical devices**

Repair and maintenance to electrical components shall include initial safety checks and component inspection procedures. If a fault exists that could compromise safety, then no electrical supply shall be connected to the circuit until it is satisfactorily dealt with. If the fault cannot be corrected immediately but it is necessary to continue operation, an adequate temporary solution shall be used. This shall be report-

ed to the owner of the equipment so all parties are advised. Initial safety checks shall include:

- that capacitors are discharged: this shall be done in a safe manner to avoid possibility of sparking;
- that no live electrical components and wiring are exposed while charging, recovering or purging the system;
- that there is continuity of earth bonding.

### **Repairs to sealed components**

Sealed electrical components shall be replaced.

### **Repair to intrinsically safe components**

Intrinsically safe components must be replaced.

### **Cabling**

Check that cabling will not be subject to wear, corrosion, excessive pressure, vibration, sharp edges or any other adverse environmental effects. The check shall also take into account the effects of aging or continual vibration from sources such as compressors or fans.

### **Detection of flammable refrigerants**

Under no circumstances shall potential sources of ignition be used in the searching for or detection of refrigerant leaks. A halide torch (or any other detector using a naked flame) shall not be used.

The following leak detection methods are deemed acceptable for all refrigerant systems.

Electronic leak detectors may be used to detect refrigerant leaks but, in the case of FLAMMABLE REFRIGERANTS, the sensitivity may not be adequate, or may need re-calibration. (Detection equipment shall be calibrated in a refrigerant-free area.) Ensure that the detector is not a potential source of ignition and is suitable for the refrigerant used. Leak detection equipment shall be set at a percentage of the LFL of the refrigerant and shall be calibrated to the refrigerant employed, and the appropriate percentage of gas (25% maximum) is confirmed.

Leak detection fluids are also suitable for use with most refrigerants but the use of detergents containing chlorine shall be avoided as the chlorine may react with the refrigerant and corrode the copper pipe-work.

If a leak is suspected, all naked flames shall be removed/extinguished.

If a leakage of refrigerant is found which requires brazing, all of the refrigerant shall be recovered from the system, or isolated (by means of shut off valves) in a part of the system remote from the leak. Removal of refrigerant shall be according to Removal and evacuation.

### **Removal and evacuation**

When breaking into the refrigerant circuit to make repairs – or for any other purpose –conventional procedures shall be used. However, for flammable refrigerants it is important that best practice be followed, since flammability is a consideration. The following procedure shall be adhered to:

- safely remove refrigerant following local and national regulations;
- evacuate;
- purge the circuit with inert gas (optional for A2L);
- evacuate (optional for A2L);
- continuously flush or purge with inert gas when using flame to open circuit; and
- open the circuit.

The refrigerant charge shall be recovered into the correct recovery cylinders if venting is not allowed by local and national codes. For appliances containing flammable refrigerants, the system shall be purged with oxygen-free nitrogen to render the appliance safe for flammable refrigerants. This process might need to be repeated several times. Compressed air or oxygen shall not be used for purging refrigerant systems.

For appliances containing flammable refrigerants, refrigerants purging shall be achieved by breaking the vacuum in the system with oxygen-free nitrogen and continuing to fill until the working pressure is achieved, then venting to atmosphere, and finally pulling down to a vacuum (optional for A2L). This pro-

cess shall be repeated until no refrigerant is within the system (optional for A2L). When the final oxygen-free nitrogen charge is used, the system shall be vented down to atmospheric pressure to enable work to take place.

The outlet for the vacuum pump shall not be close to any potential ignition sources, and ventilation shall be available.

### **Charging procedures**

In addition to conventional charging procedures, the following requirements shall be followed.

- Ensure that contamination of different refrigerants does not occur when using charging equipment. Hoses or lines shall be as short as possible to minimise the amount of refrigerant contained in them.
- Cylinders shall be kept in an appropriate position according to the instructions.
- Ensure that the REFRIGERATING SYSTEM is earthed prior to charging the system with refrigerant
- Label the system when charging is complete (if not already).
- Extreme care shall be taken not to overfill the REFRIGERATING SYSTEM.  
Prior to recharging the system, it shall be pressure-tested with the appropriate purging gas. The system shall be leak-tested on completion of charging but prior to commissioning. A follow up leak test shall be carried out prior to leaving the site.

### **Decommissioning**

Before carrying out this procedure, it is essential that the technician is completely familiar with the equipment and all its detail. It is recommended good practice that all refrigerants are recovered safely. Prior to the task being carried out, an oil and refrigerant sample shall be taken in case analysis is required prior to re-use of recovered refrigerant. It is essential that electrical power is available before the task is commenced.

- a) Become familiar with the equipment and its operation.
- b) Isolate system electrically.
- c) Before attempting the procedure, ensure that:
  - mechanical handling equipment is available, if required, for handling refrigerant cylinders;
  - all personal protective equipment is available and being used correctly;
  - the recovery process is supervised at all times by a competent person;
  - recovery equipment and cylinders conform to the appropriate standards.
- d) Pump down refrigerant system, if possible.
- e) If a vacuum is not possible, make a manifold so that refrigerant can be removed from various parts of the system.
- f) Make sure that cylinder is situated on the scales before recovery takes place.
- g) Start the recovery machine and operate in accordance with instructions.
- h) Do not overfill cylinders (no more than 80% volume liquid charge).
- i) Do not exceed the maximum working pressure of the cylinder, even temporarily.
- j) When the cylinders have been filled correctly and the process completed, make sure that the cylinders and the equipment are removed from site promptly and all isolation valves on the equipment are closed off.
- k) Recovered refrigerant shall not be charged into another REFRIGERATING SYSTEM unless it has been cleaned and checked

### **Labelling**

Equipment shall be labelled stating that it has been de-commissioned and emptied of refrigerant. The label shall be dated and signed. For appliances containing FLAMMABLE REFRIGERANTS, ensure that there are labels on the equipment stating the equipment contains FLAMMABLE REFRIGERANT.

### **Recovery**

When removing refrigerant from a system, either for servicing or decommissioning, it is recommended good practice that all refrigerants are removed safely.

When transferring refrigerant into cylinders, ensure that only appropriate refrigerant recovery cylinders

are employed. Ensure that the correct number of cylinders for holding the total system charge is available. All cylinders to be used are designated for the recovered refrigerant and labelled for that refrigerant (i.e. special cylinders for the recovery of refrigerant). Cylinders shall be complete with pressure-relief valve and associated shut-off valves in good working order. Empty recovery cylinders are evacuated and, if possible, cooled before recovery occurs.

The recovery equipment shall be in good working order with a set of instructions concerning the equipment that is at hand and shall be suitable for the recovery of the flammable refrigerant. If in doubt, the manufacturer should be consulted. In addition, a set of calibrated weighing scales shall be available and in good working order. Hoses shall be complete with leak-free disconnect couplings and in good condition.

The recovered refrigerant shall be processed according to local legislation in the correct recovery cylinder, and the relevant waste transfer note arranged. Do not mix refrigerants in recovery units and especially not in cylinders.

If compressors or compressor oils are to be removed, ensure that they have been evacuated to an acceptable level to make certain that flammable refrigerant does not remain within the lubricant. The compressor body shall not be heated by an open flame or other ignition sources to accelerate this process. When oil is drained from a system, it shall be carried out safely.

## 2. Considerations of Unit Location

### 2.1 Unit Size

**Table 2.1 Outdoor Operating Temperature**

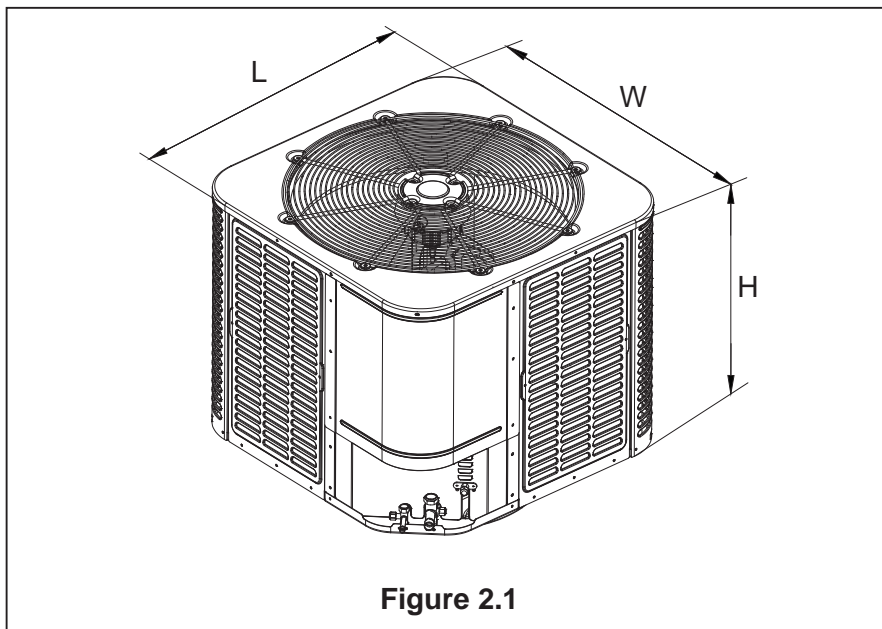
Model	Temperature
Cooling mode	54~118°F
General heat pump mode	5~80°F
High vertical / Long line heat pump mode	14~80°F

**Table 2.2**

Model	Unit size(H × W × L (inches))
18K AC&HP, 24K AC&HP, 30K AC	25 × 21-4/5 × 21-4/5
30K HP, 36K AC&HP	25 × 29-1/7 × 29-1/7
42K/48K/60K AC&HP	32-7/8 × 29-1/7 × 29-1/7

The weight of the unit is attached to the carton.

When installing the outdoor unit on the roof, make sure that the roof can support the weight of the outdoor unit. It is recommended to choose appropriate isolation to prevent sound or vibration from being transmitted to the building structure.



## 2.2 Refrigerant Pipeline Restriction

**Table 2.3 General Mode**

Refrigerant Piping		Capacity (Btu/h)						
		18K	24K	30K	36K	42K	48K	60K
Liquid-Vapor	In.	3/8-3/4	3/8-3/4	3/8-3/4	3/8-3/4	3/8-7/8	3/8-7/8	3/8-7/8
Max. Refrigerant Line Length*	Ft.	100						
Max. Vertical Lift	Ft.	26						

\* It is recommended to adopt standard pipeline size; Refrigerant charge: see Section 14.

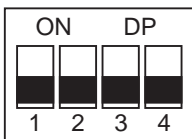


- If the pipeline length or high vertical of the above models exceeds the data in Table 2.3, this is long lineset. For HP units, please set the high vertical mode dip switch according to the data range in Table 2.4, and refer to Table 2.5 for the dip switch diagram. For AC units, no need additional setup.

**Table 2.4 High Vertical Mode**

Refrigerant Piping		Capacity (Btu/h)							
		18K	24K	30K	36K	42K	48K	60K	
Liquid-Vapor	In.	3/8-3/4	3/8-3/4	3/8-3/4	3/8-3/4	3/8-7/8	3/8-7/8	3/8-7/8	
Max. Refrigerant Line Length*	Ft.	131					147		
Max. Vertical Lift	Ft.	65					65		

\* It is recommended to adopt standard pipeline size; Refrigerant charge: see Section 14.

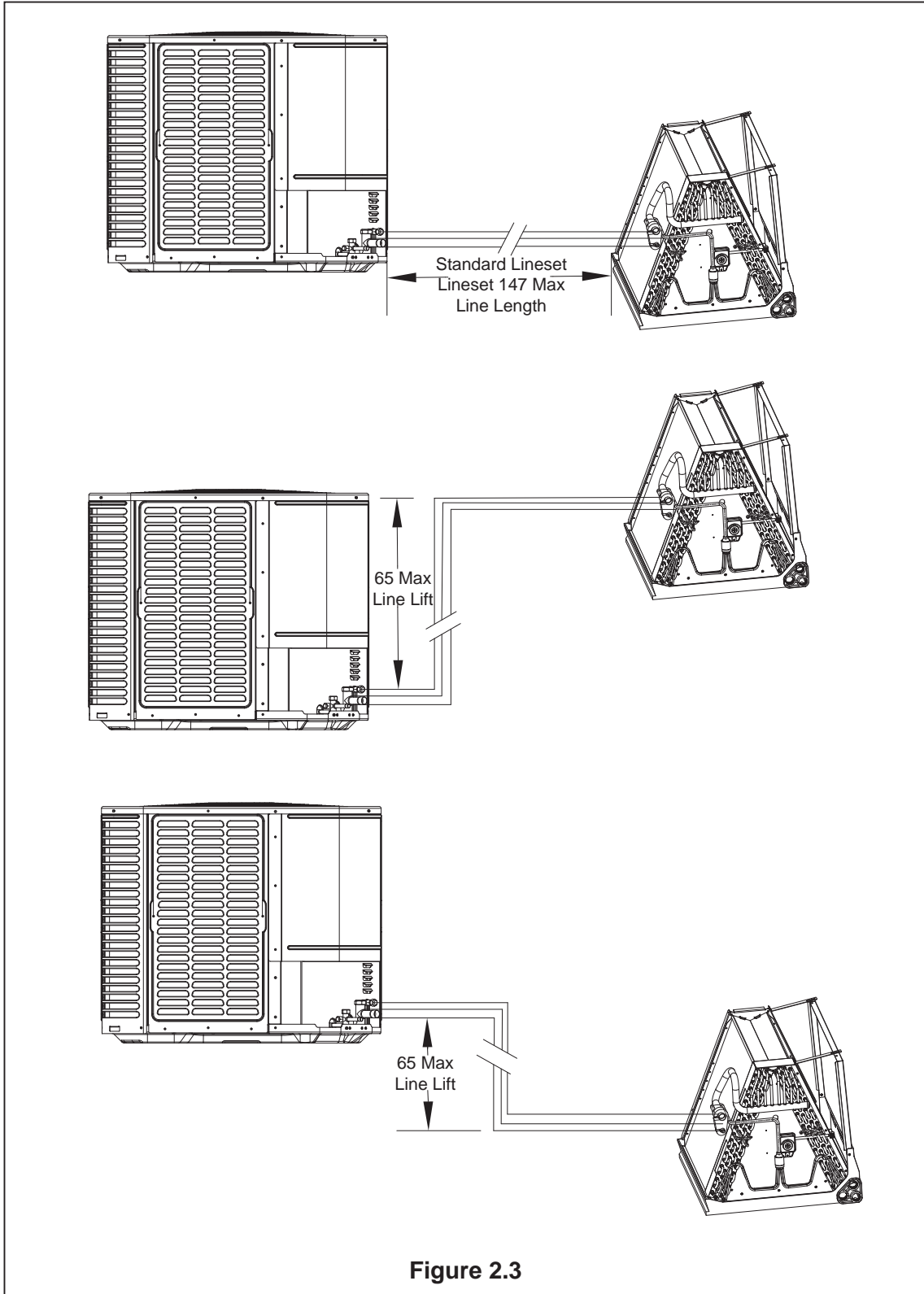


**Figure 2.2**

**Table 2.5 Dip Switch Diagram (Only for HP Units)**

Dial switch	ON	OFF
SW2-4	High vertical mode	General mode

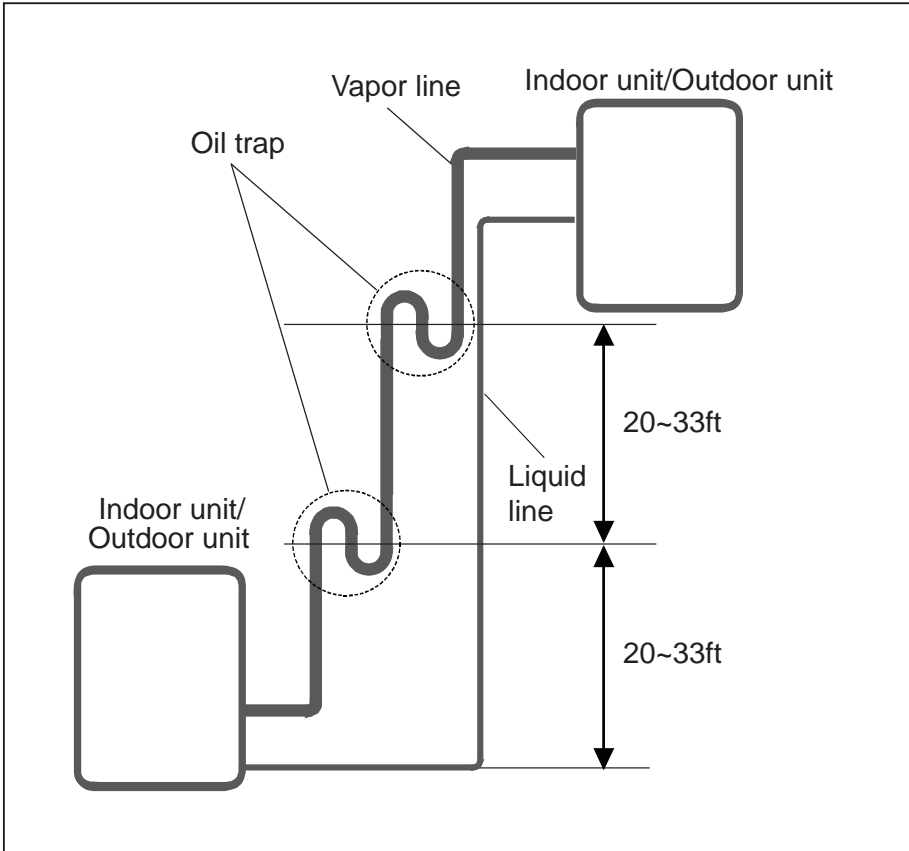
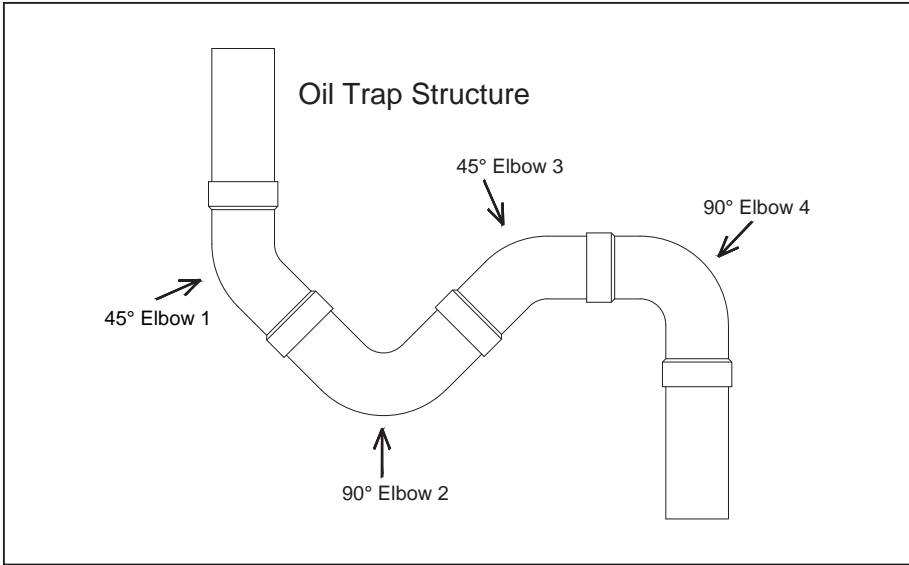
- ▶ Maximum equivalent length of pipeline = 131 feet(18K/24/30K/36K/42K).
- ▶ Maximum equivalent length of pipeline = 147 feet(48K/60K).
- ▶ Maximum vertical equivalent length = 65 feet.
- ▶ Use only the pipe diameters shown in Table 2.3.
- ▶ If the suction line exceeds 65 feet, do not use a larger suction line than recommended.



### 2.3 Long Line Installation Precautions

- If all long lines are in a horizontal state, no additional measures are required;
- If there is a vertical height difference in the long line, it needs to be installed according to the following requirements:
- For HP units, an oil trap needs to be installed every 20~33 ft.

**NOTE:** The vertical height between the outdoor unit and the indoor unit depends on different model. The MAX line length of 18K/24K/30K/36K/42K is 131 feet, the MAX line length of 48K/60K is 147 feet. The following is the connection method of the oil return trap.

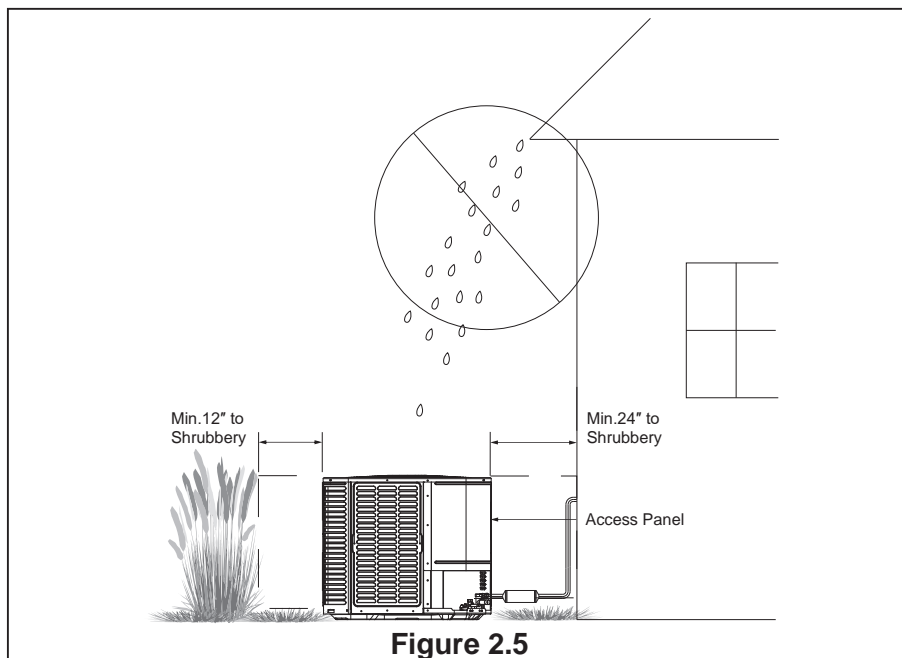
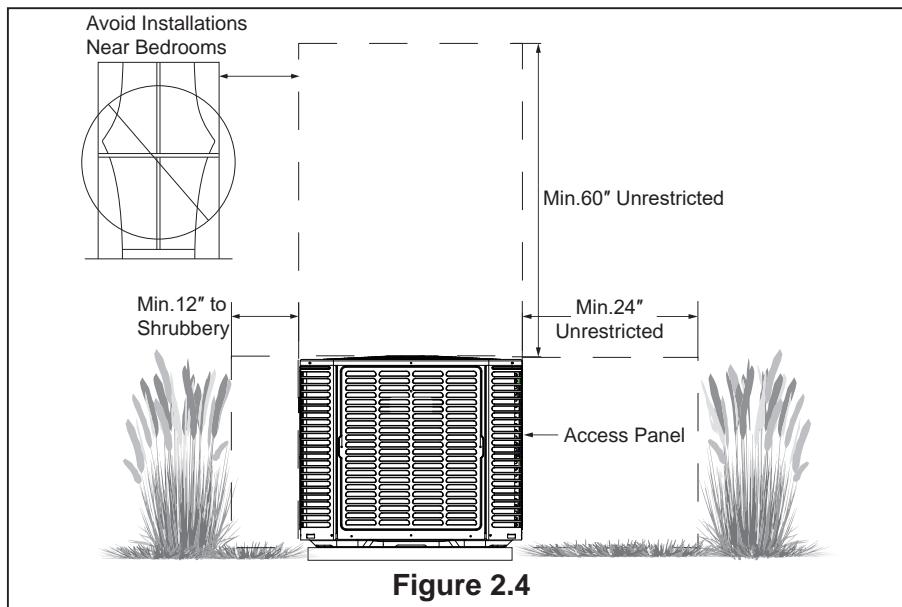


## 2.4 Position Restriction



- The outdoor unit shall be located in a well-ventilated location other than the occupied space, such as in the open air.
- For installation of the indoor unit, refer to the corresponding installation introductions. If an indoor unit is installed in an unventilated area, the area shall be so constructed that should any refrigerant leak, it will not stagnate so as to create a fire or explosion hazard.

- Make sure that the discharge area at least 60 inches above the top of the unit is unrestricted.
- Don't put the outdoor unit near the bedroom, because the normal operating sound may be offensive.
- Position the equipment, leaving enough space for smooth airflow, wiring, refrigerant lines and maintainability.
- Allow a minimum of 12 in. clearance on one side of control board access panel to a wall and a minimum of 24 in. on the adjacent side of control board access panel.
- Keep a distance of 24 inches between adjacent units.
- Place the unit in a place where water, snow or ice cannot fall directly on the device from the roof or overhangs.
- See figures 2.4 and 2.5.

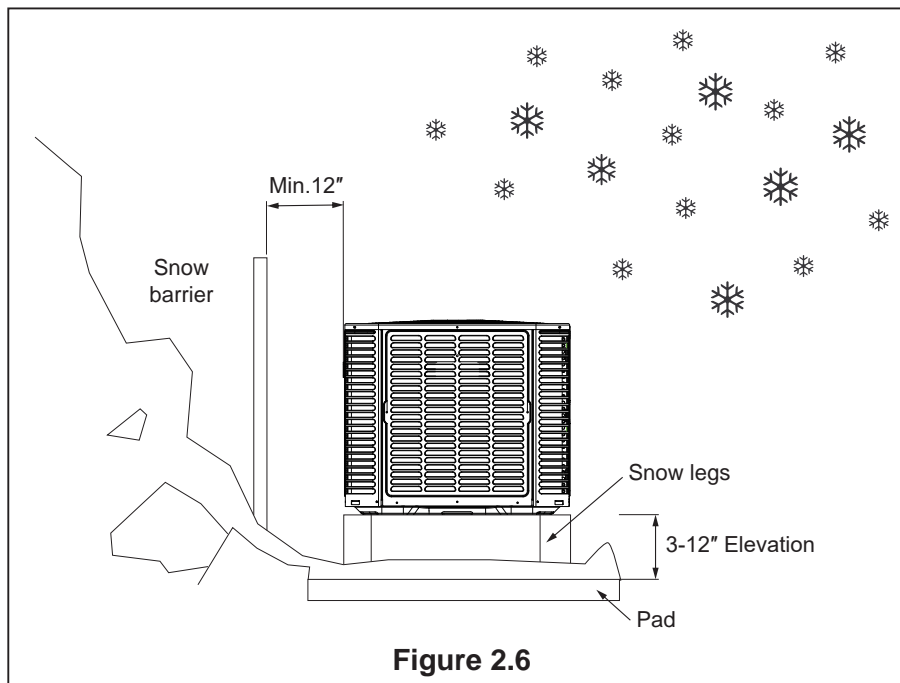


## Precautions in cold climate



Precautions must be taken for units installed in areas with snow and long-term temperatures below freezing point.

- Depending on the local weather conditions, the unit should be raised by 3-12 inches. This extra height will allow the snow and ice melted during the defrosting cycle to be discharged before re-freezing. Make sure that the drain hole on the unit chassis is not blocked, otherwise it will hinder the defrosting water discharge (Figure 2.6).
- If possible, avoid places that are prone to snow. If this is not feasible, a snow barrier should be installed around the unit to prevent snow accumulation on the side of the unit.



## Corrosive Environment

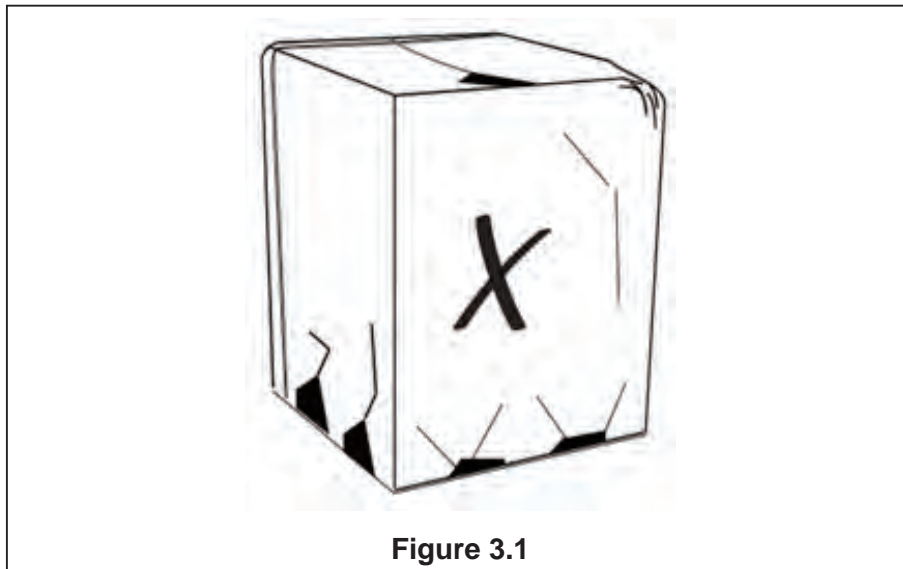
Exposure to corrosive environment may shorten the service life of unit, corrode metal parts and/or negatively affect the performance of unit. Corrosive elements include but are not limited to: sodium chloride, sodium hydroxide, sodium sulfate and other compounds commonly found in seawater, sulfur, chlorine, fluorine, fertilizers and various chemical pollutants from industrial/manufacturing plants. If it is installed in an area that may be exposed to corrosive environment, special attention should be paid to the placement and maintenance of the unit.

- Lawn sprinklers/hoses/waste water should not be sprayed directly on the outer panel of the unit for a long time.
- In coastal areas: install the unit on the side away from the waterfront.
- Fences or shrubs can provide some shielding protection for the unit, but the minimum device clearance must still be kept.
- Clean the outdoor coil and any exposed external surfaces about every three months.

## 3. Unit Installation Preparation

### 3.1 Prepare the Unit for Installation

- Check whether there is any damage and report any damage to the unit to the carrier in time (Figure 3.1).
- The charge port can be used to ensure that the refrigerant charge is maintained during shipment.
- Refrigerant Leak detectors must be designed to detect R454B.
- Recovery equipments (including refrigerant recovery containers) must be designed to handle R454B.
- If using TXV, TXV should be designed to compatible with R454B.



## 4. Unit Settings

### 4.1 Pad Installation

When installing the unit on a support pad (such as a concrete slab), please consider the following:

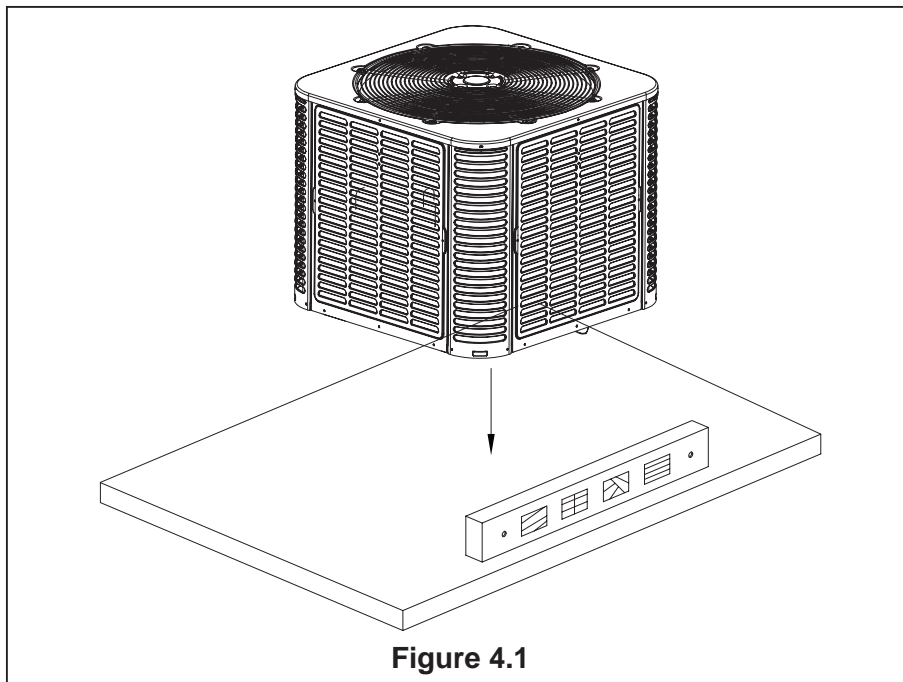
- All sides of the pad must be at least 1-2 inches larger than the unit.
- The pad must be separated from any structure.
- The pad must be level.
- The pad must be high enough above the ground for drainage.
- The location of the pad must comply with national, state and local regulations.



These instructions are intended to provide a method of fixing the system to the cement slab as a fixing procedure in windy areas. Check the local regulations of tie-down methods and protocols.



- The outdoor unit suction pipe service valve and liquid pipe service valve need to be protected.
- Do not grab them when moving the unit.



## 5. Precautions for Refrigerant Pipeline

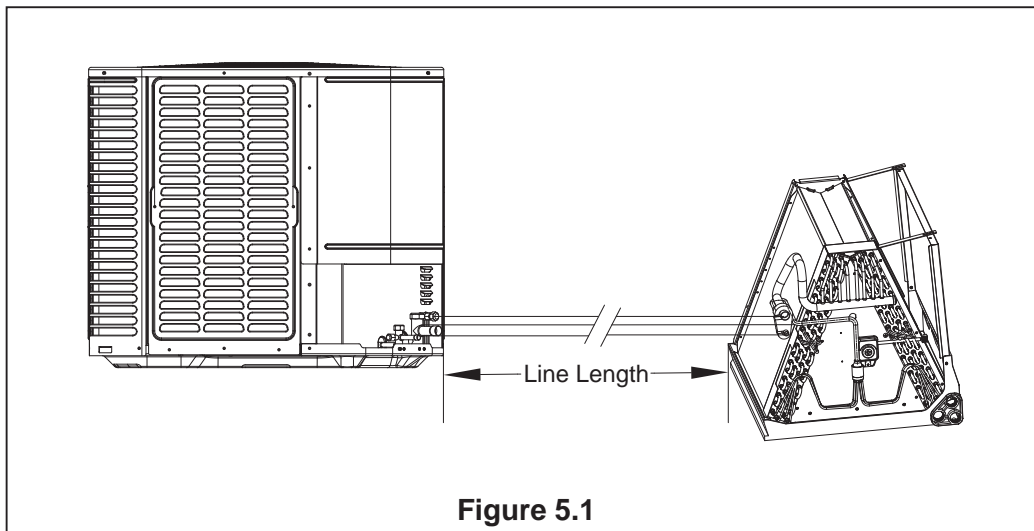
### 5.1 Connecting Dimensions of Refrigerant Lines and Service Valves

Table 5.1

Model	Suction line	Liquid line	Suction line connection	Liquid line connection
	The dimensions are in inches.			
18K/24K/30K/36K	3/4	3/8	3/4	3/8
42K/48K/60K	7/8	3/8	7/8	3/8

### 5.2 Required Refrigerant Line Length

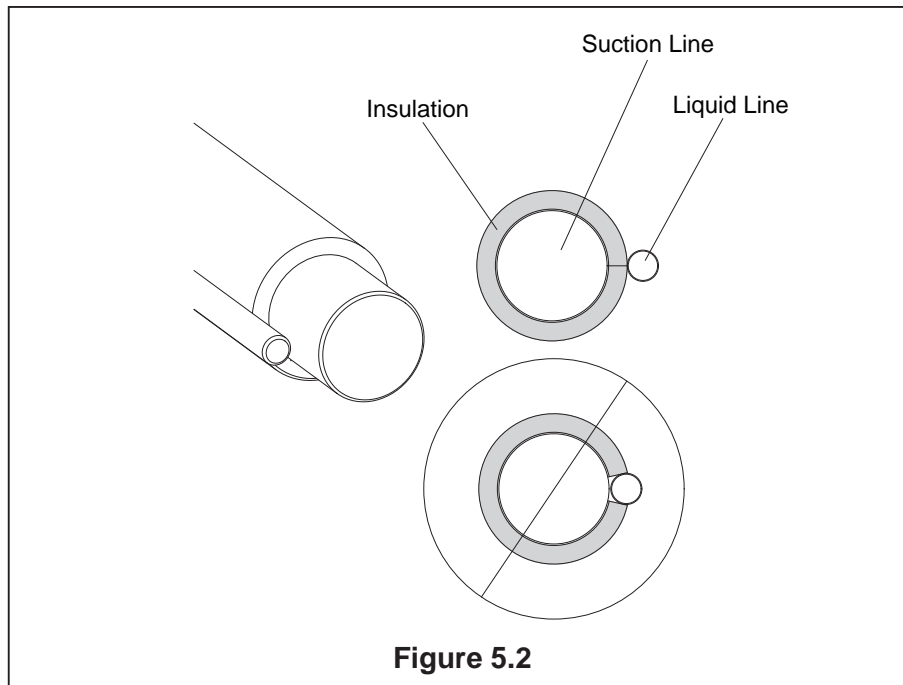
Determine the required pipeline length (Figure 5.1). Please refer to Section 2.2.



### 5.3 Refrigerant Pipe Insulation



The refrigerant pipe must always be insulated. Do not let the liquid line and suction line come into direct contact (metal to metal).



## 5.4 Reuse the Existing Refrigerant Lines



### Note: Mild to moderate burns

- If using existing refrigerant lines, make sure that all joints are brazed, not soldered.

The following precautions should be taken for the retrofit application that will use the existing refrigerant pipeline:

- Make sure the refrigerant line size is correct. Refer to Section 2.2 and Table 2.3.
- Make sure the refrigerant line is free of leakage, acid and oil.
- Using existing lines that have been used with other refrigerants is not recommended.



The manufacturer recommends that only approved matching indoor and outdoor systems be installed. All split systems of the manufacturer are AHRI-rated. The benefits of installing an approved indoor and outdoor split system are maximum efficiency, best performance and best overall system reliability.

## 6. Refrigerant Pipeline Routing

### 6.1 Preventive Measure

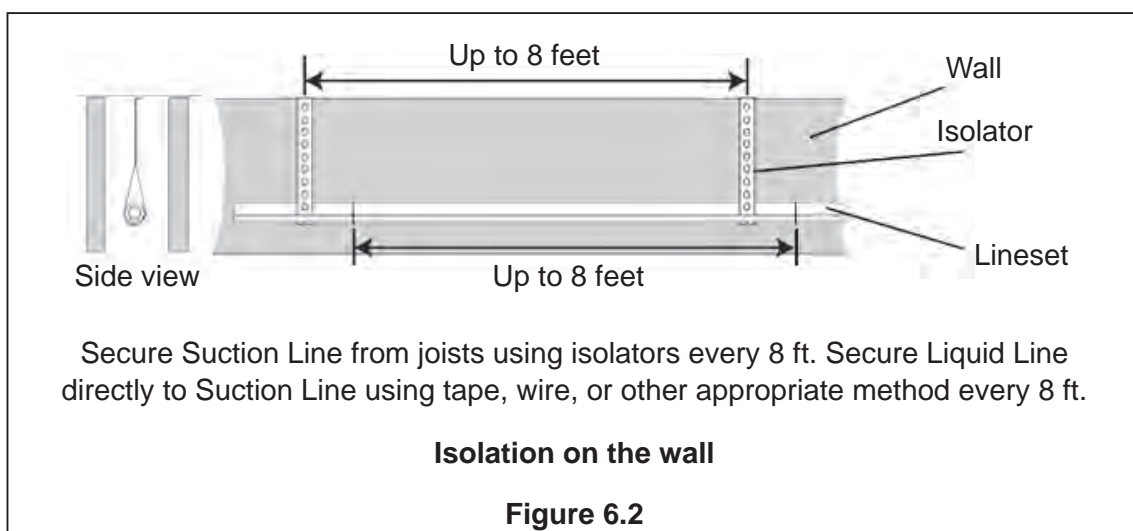
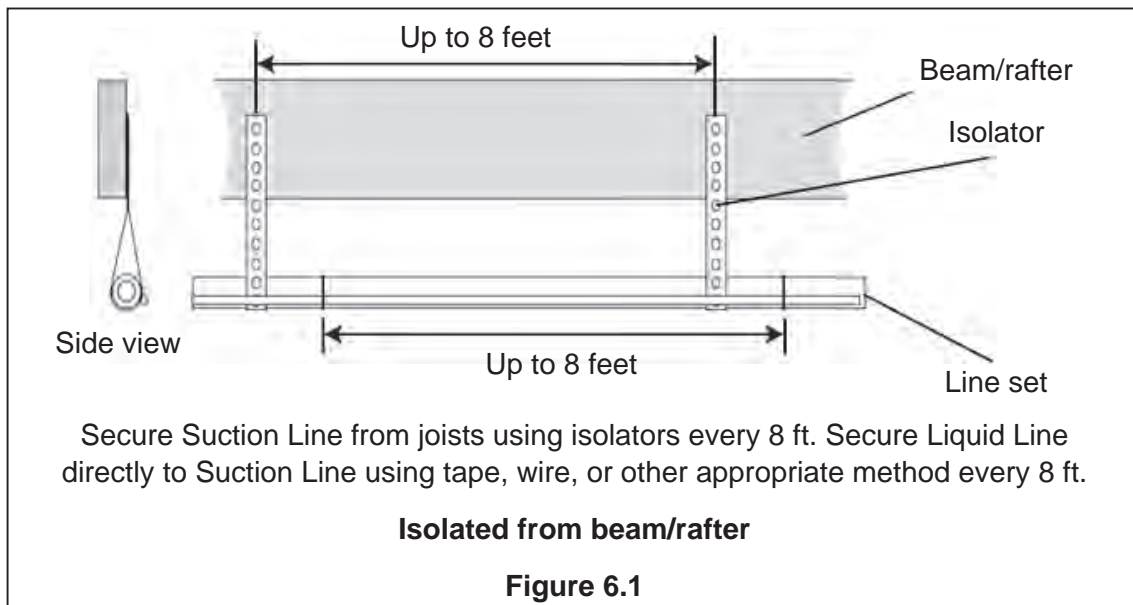
Take preventive measures to prevent noise generated by vibration transmission of refrigerant

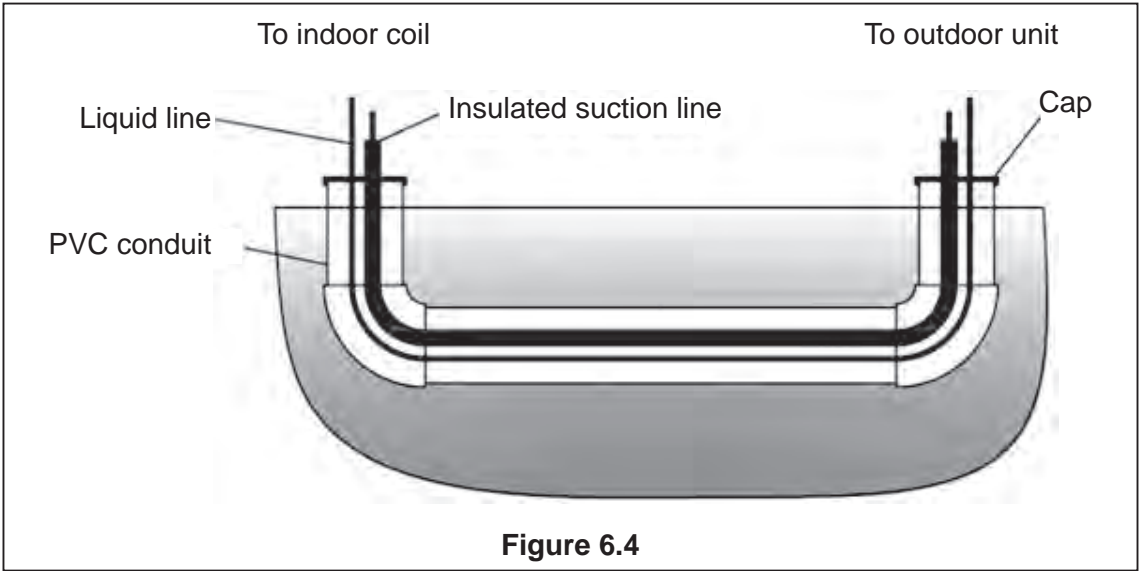
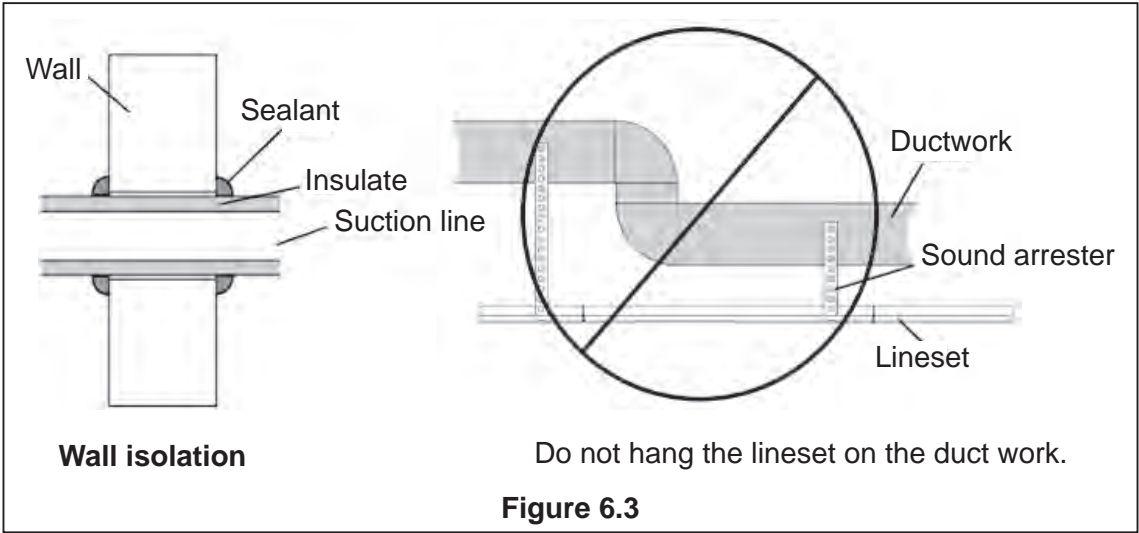
line in building structure. For example:

- When the refrigerant line must be fixed on floor joists or other frames in the structure, use isolated hangers.
- When the refrigerant line runs in the column space or closed ceiling, the isolation hanger should also be used.
- When refrigerant lines pass through walls or windowsills, they should be insulated and isolated.
- Isolate the line from all ductwork systems.
- Try to reduce the number of 90° turn.



Comply with national, state and local regulations when isolating the wire group from joists, rafters, walls or other structural elements.





# 7. Refrigerant Line Brazing

## 7.1 Brazed Refrigerant Pipeline



- Pipe work and installation shall be in compliance with national codes ASHRAE15.
- It is recommended to install a filter dryer, this filter dryer should be compatible with R454B refrigerant.

1. Remove the cover or plug. Use the deburring tool to deburr the line end. Clean the inner and outer surfaces of the pipeline with emery cloth.

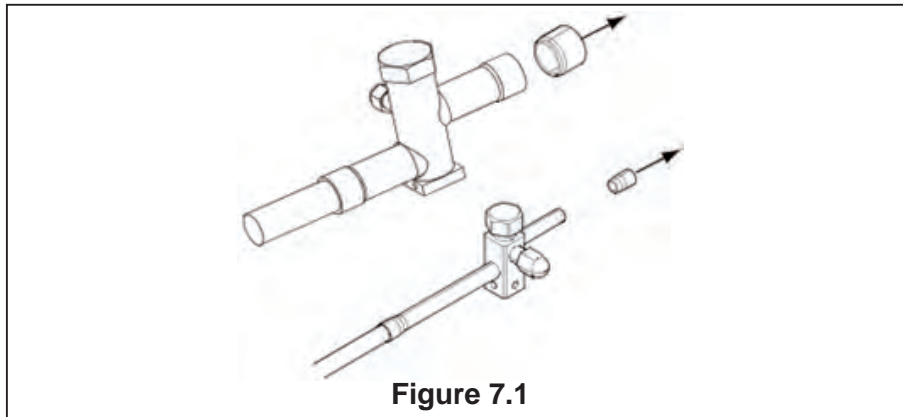


Figure 7.1

2. Remove the pressure taps from the two service valves.

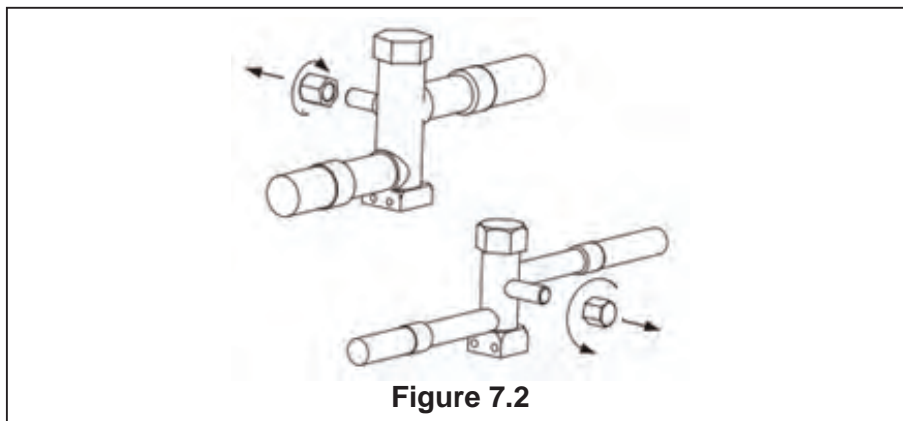


Figure 7.2

3. Purge refrigerant lines and indoor coils with dry nitrogen.

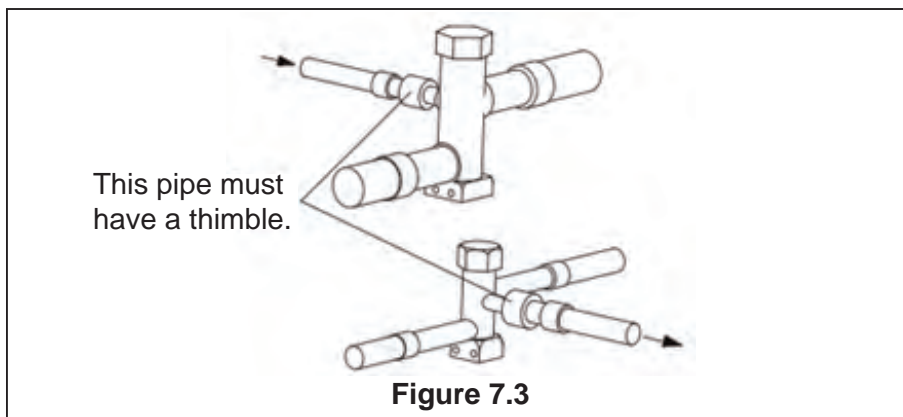


Figure 7.3

4. Wrap the valve body with a wet rag to avoid thermal damage, and continue the dry nitrogen purging (Figure 7.4).

Braze the refrigerant line to the service valve.

Braze the filter drier to the liquid line.

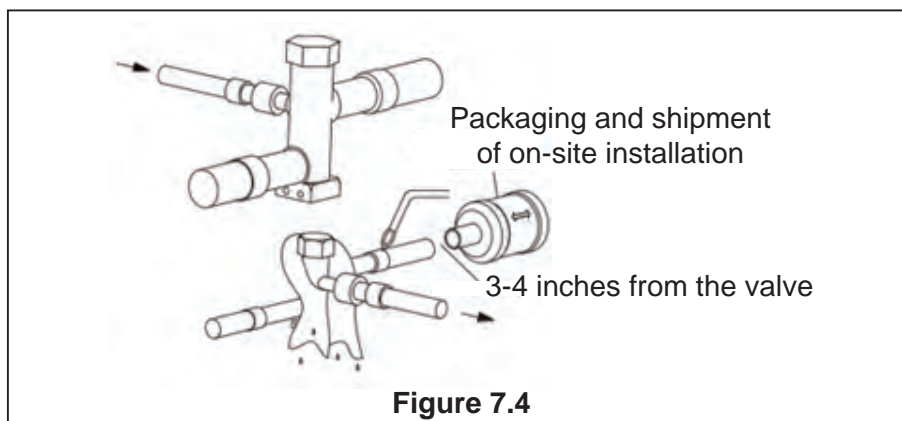


All units are recommended to install bidirectional filter driver. Braze the filter drier to the liquid line, taking care not to push the refrigerant line too hard through the stopper in the filter drier (this may damage the filter).

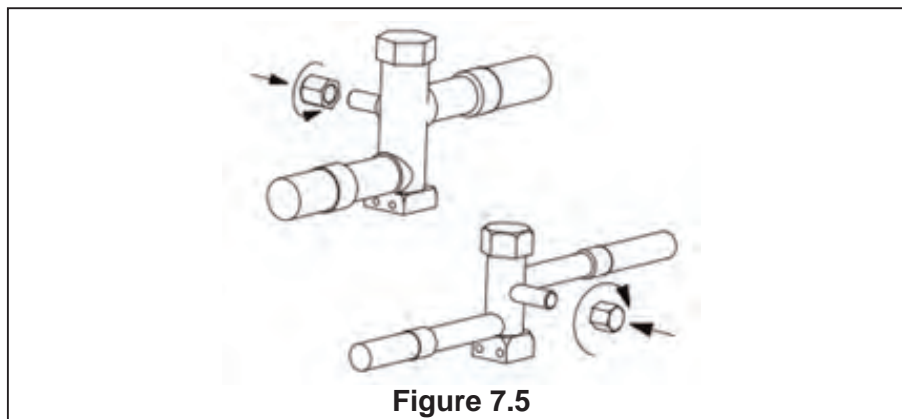
Continue the dry nitrogen purge. Don't take off the wet rag before all brazing is completed.



Before stopping the dry nitrogen purge, please remove the wet rag.



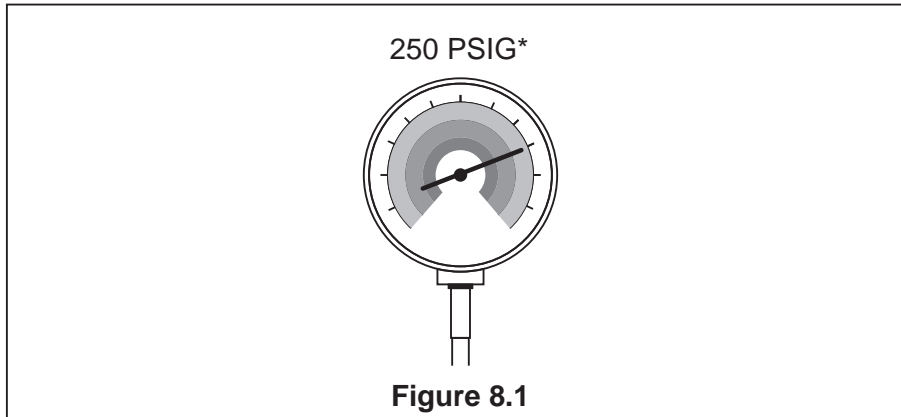
5. After the service valve cools down, put back the pressure tap.



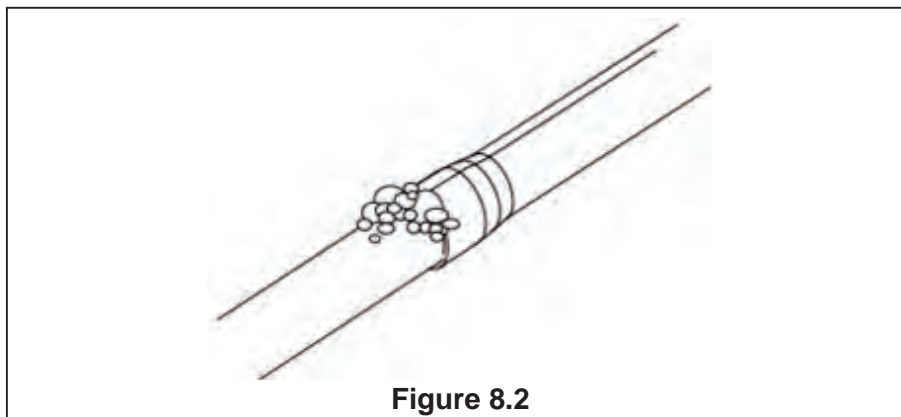
## 8. Refrigerant Line Leakage Inspection

### 8.1 Check for Leaks

1. Use dry nitrogen to pressurize the refrigerant line and evaporator coil to 250 PSIG\*.



2. Use soapy water or bubbles at each brazing position to check for leaks.



#### \*Note:

- After completion of field piping for split systems, the field pipework shall be pressure tested with an inert gas and then vacuum tested prior to refrigerant charging. The minimum test pressure for the system shall be the low side design pressure (See nameplate for details).



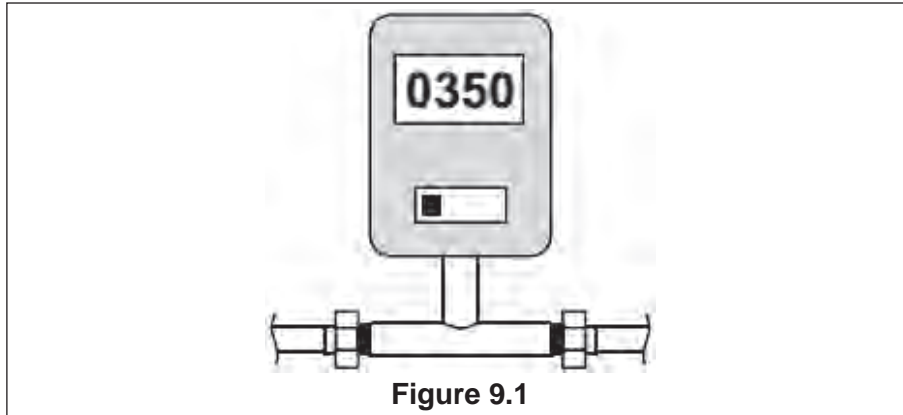
## 9. Vacuuming

### 9.1 Drain Refrigerant Lines and Indoor Coils



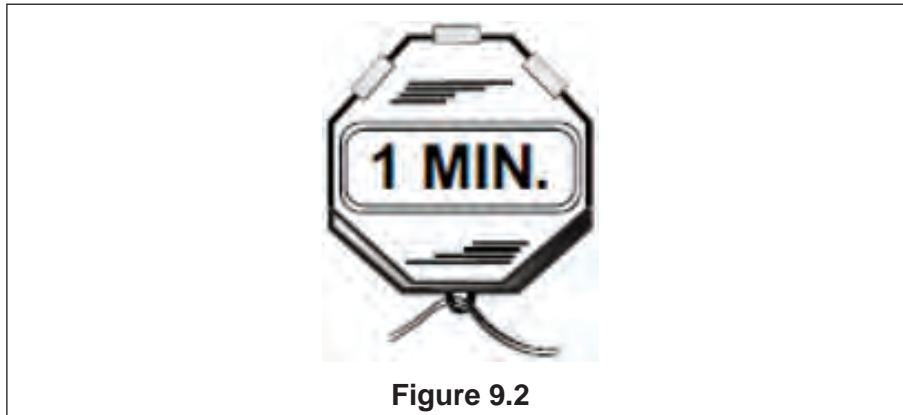
Do not open the service valve until the leakage inspection and vacuuming of refrigerant lines and indoor coils are completed.

1. Evacuate until the micron gauge reads no higher than 350 microns, then close the valve to the vacuum pump.



2. Observe micron gauge. If the micrometer meter does not rise above 500 microns within one (1) minute, the evacuation is completed.

After the evacuation, turn off the vacuum pump and micron gauge, and close the valve on the manifold instrument cluster.



# 10. Service Valve

## 10.1 Open the Service Valve



### Warning: Moderate to severe burns

- When opening the liquid line service valve, be extra careful. Turn counterclockwise until the valve stem just touches the hem. No torque is required. Failure to observe this warning will result in sudden release of system pressure, and may result in personal injury and/or property damage.

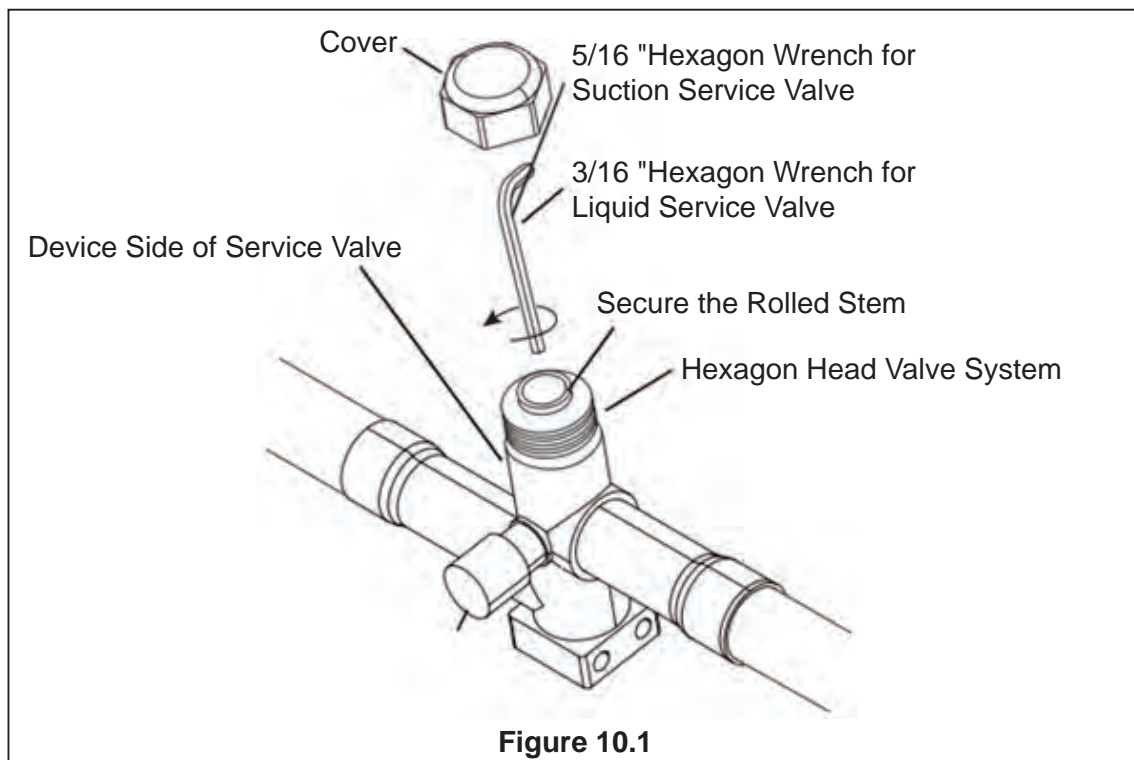


Before opening the service valve, the leakage inspection and evacuation must be completed. The valve of copper welded pipe installation should be used for leakage inspection and vacuum pumping. The use of a separate suction port in this process will lead to refrigerant loss.



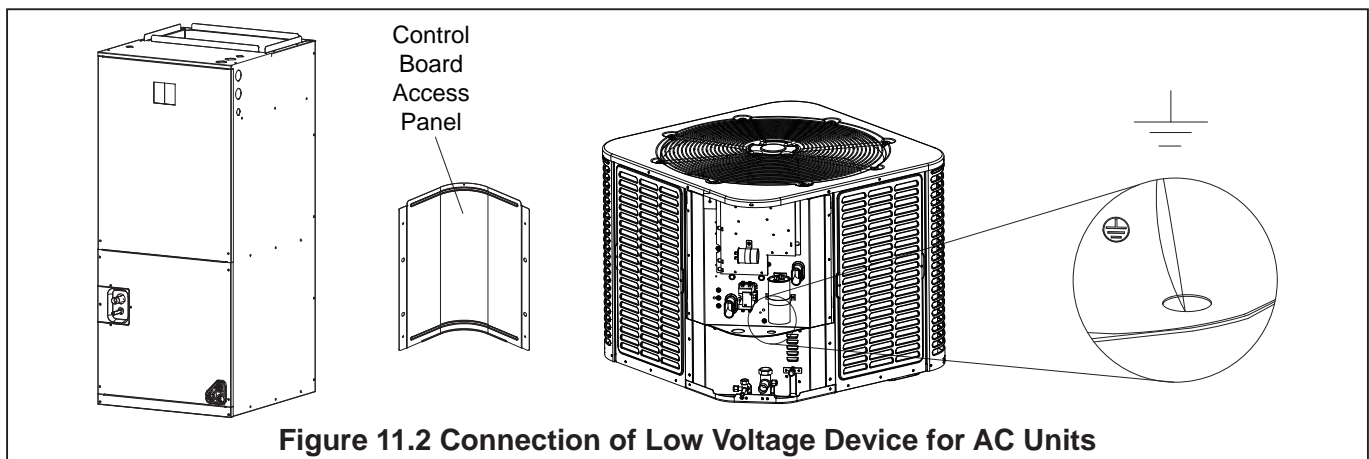
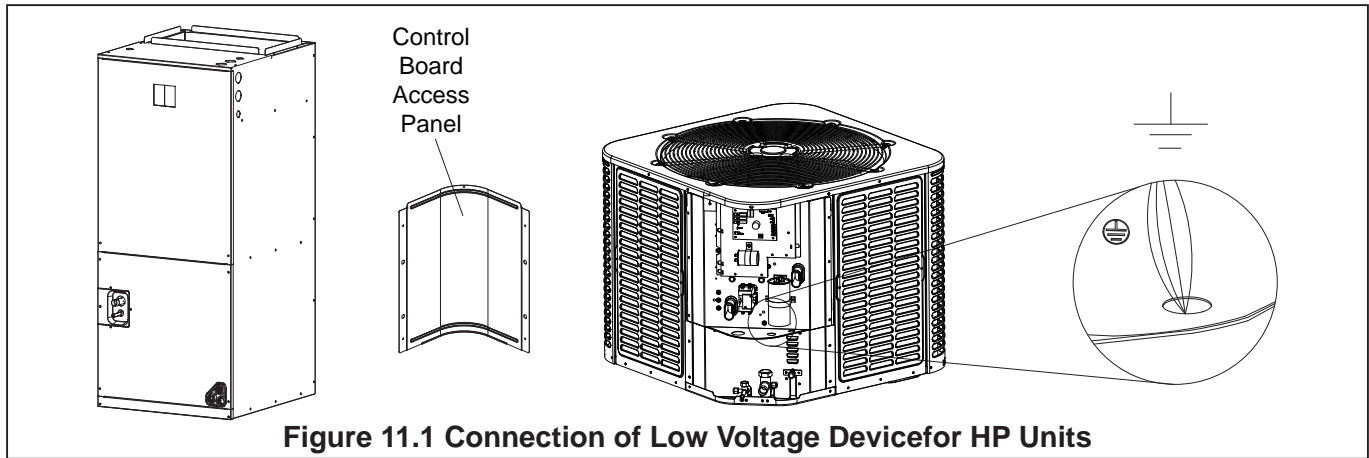
Before opening the liquid service valve, the suction service valve must be opened first.

1. Remove the valve cover (Figure 10.1).
2. Insert the hex wrench into the valve stem completely and back out counterclockwise until the valve stem just touches the bead (about five (5) turns.)
3. Replace the valve stem cap to prevent leakage. Tighten it with your fingers and turn it for another 1/6 turn.
4. Repeat steps 1-3 for the liquid service valve.



# 11. Electrical-Low Voltage

## 11.1 Low Voltage Connection Diagram



## 11.2 Wiring Diagram of Thermostat

- Ensure that the power supply is consistent with the nameplate of the unit.
- The power connection and grounding of the unit must comply with local regulations.
- Low voltage wiring to be No. 22 AWG minimum conductor.
- "-----" On-site installation of electrical auxiliary heat connection
- Single-stage electric auxiliary heating supported by 2H thermostat
- Two-stage electric auxiliary heating supported by 3H thermostat
- W1: The first stage of electric auxiliary heating installed in the indoor unit.
- W2: The second stage of electric auxiliary heating installed in the indoor unit.
- The W signal of the HP outdoor unit is connected to the electric auxiliary heating or the first-stage electric auxiliary heat. AC outdoor unit has no W signal terminal.



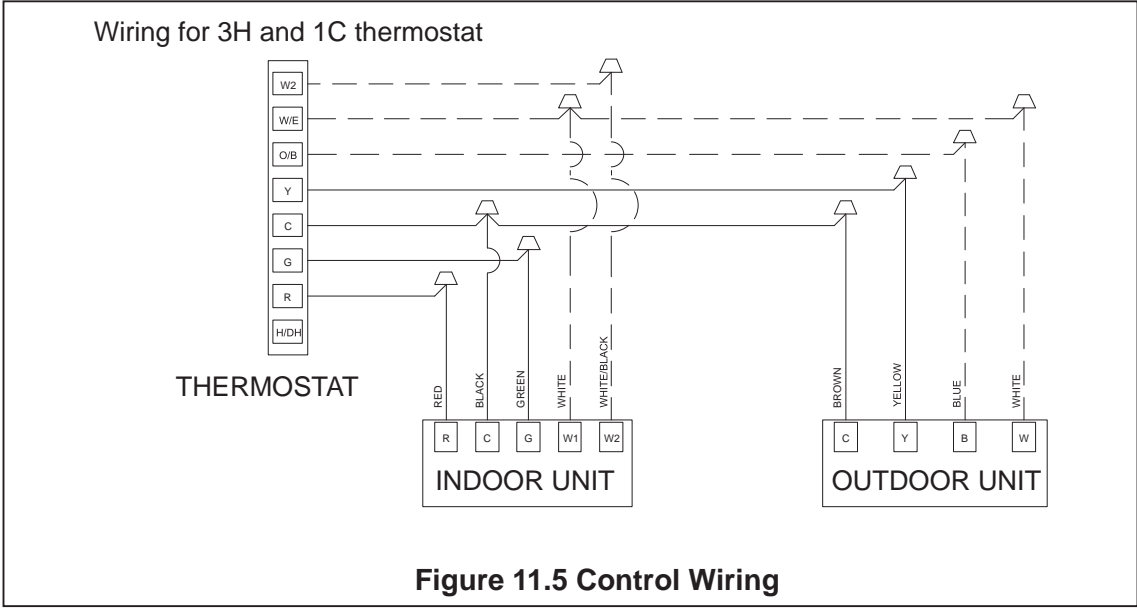
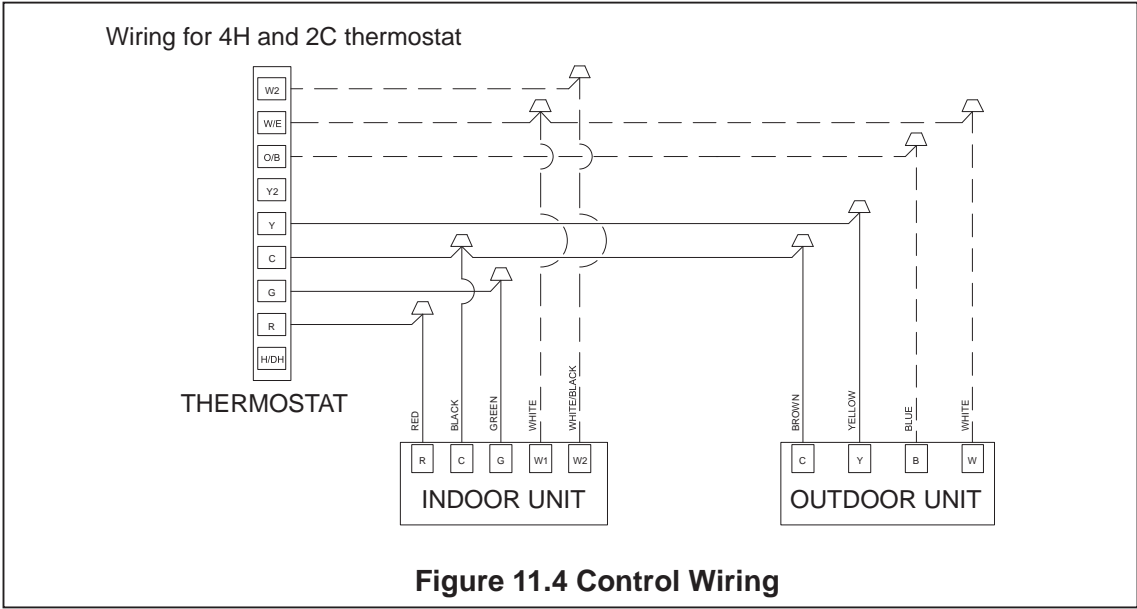
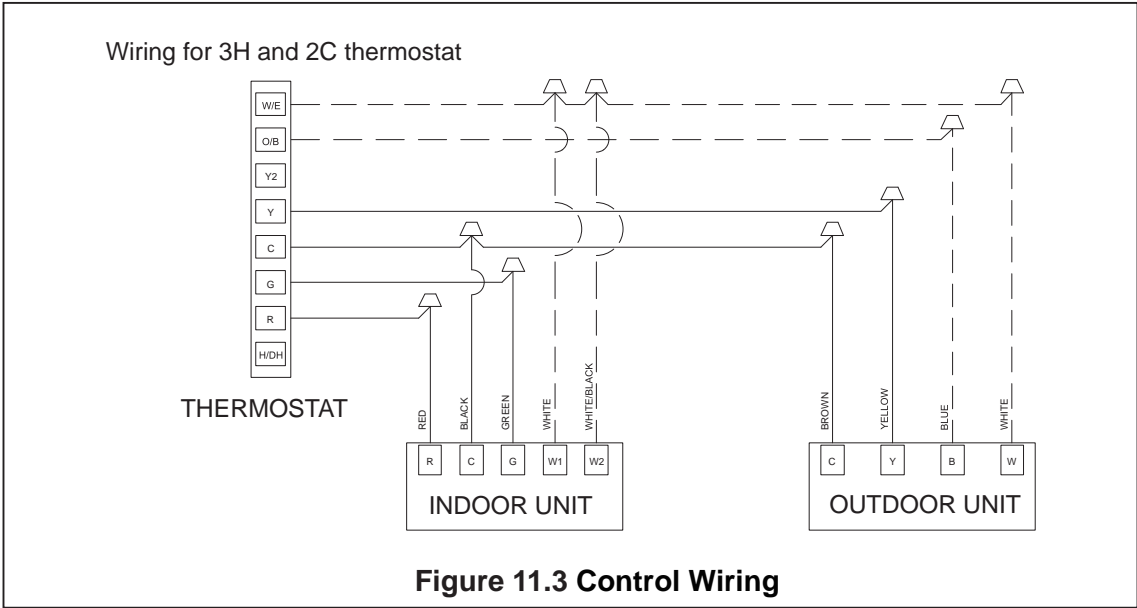
The dotted line in the following thermostat wiring diagram indicates optional wiring (wiring for passive dehumidification and/or electric heating). For the wiring of the thermostat, please refer to the user manual of the thermostat.



The reversing valve is energized in heating mode and de-energized in cooling mode. As factory default, O/B terminal and reversing valve are set to be energized at the same time.



If there are 2 or more systems (communication) in the same area, make sure the low voltage wires are connected to the right unit that are connected to the same refrigerant line. The combine indoor unit must have a R454B refrigerant sensor.



Wiring for 2H and 2C thermostat

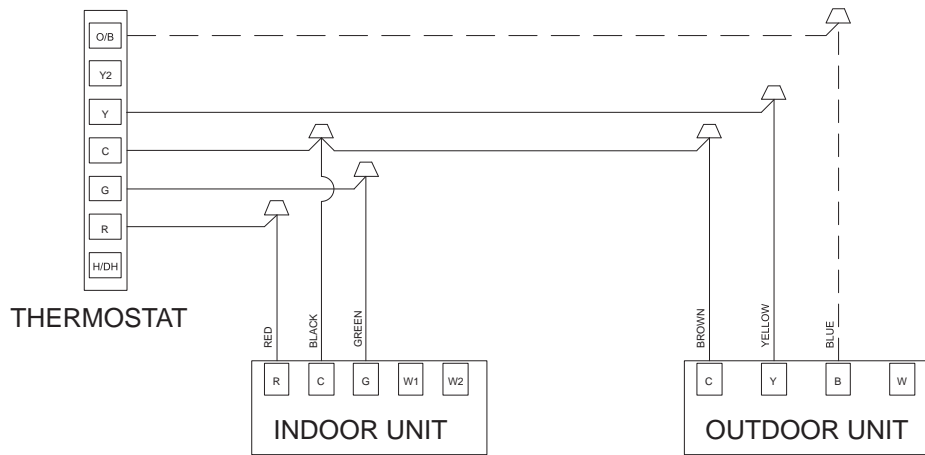


Figure 11.6 Control Wiring

Wiring for 1H and 1C thermostat

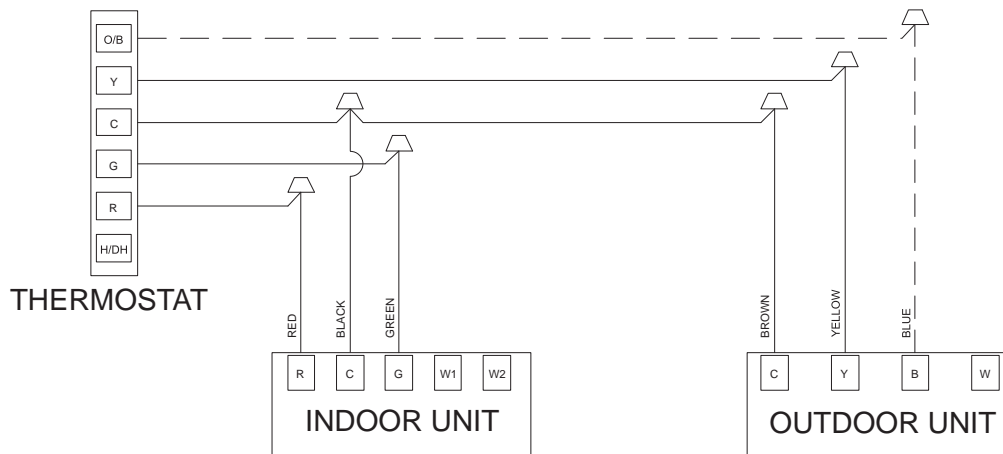


Figure 11.7 Control Wiring

Wiring for 2H and 1C thermostat

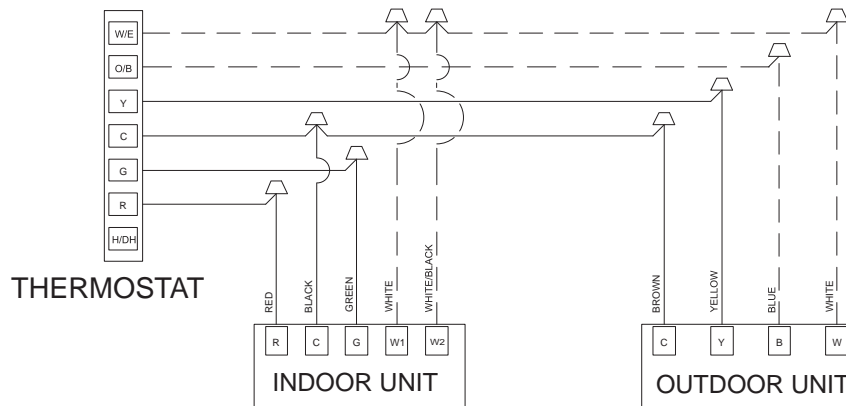


Figure 11.8 Control Wiring

## 12. Electrical-High Voltage

### 12.1 High Voltage Power Supply



#### Warning: Live electrical parts!

- During the installation, testing, maintenance and troubleshooting of this product, it may be necessary to use live electrical parts. Failure to observe all electrical safety precautions when exposed to live electrical parts may result in death or serious injury.

The high-voltage power supply must match the nameplate of the unit (208/230V, 1Ph, 60Hz).



Power supply wiring must comply with national, state and local regulations.

Follow the instructions of the unit wiring diagram located at the back side of control box access panel, and refer to the wiring diagram in this installation manual.

### 12.2 High Voltage Disconnect Switch

Install a separate disconnect switch on the outdoor unit.

High-voltage wiring must use flexible electrical conduit supplied on site.

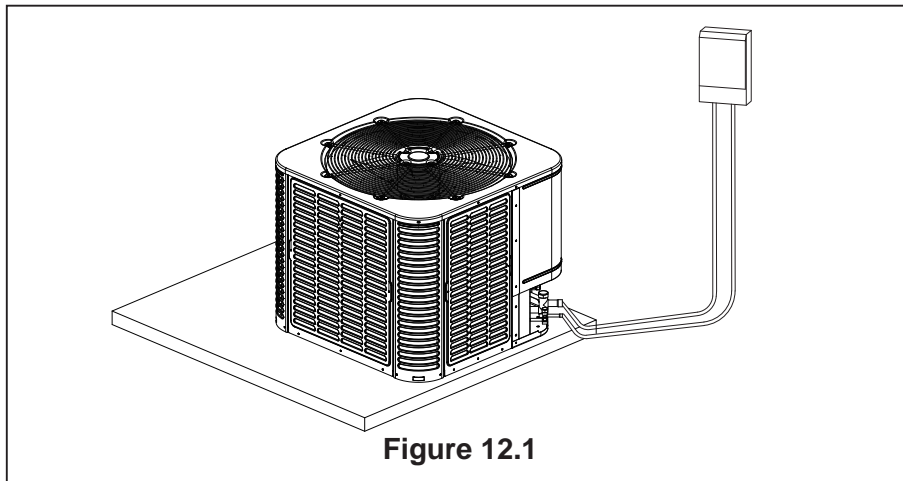


Figure 12.1

### 12.3 High Voltage Grounding

Ground the outdoor unit according to the requirements of national, state and local regulations.

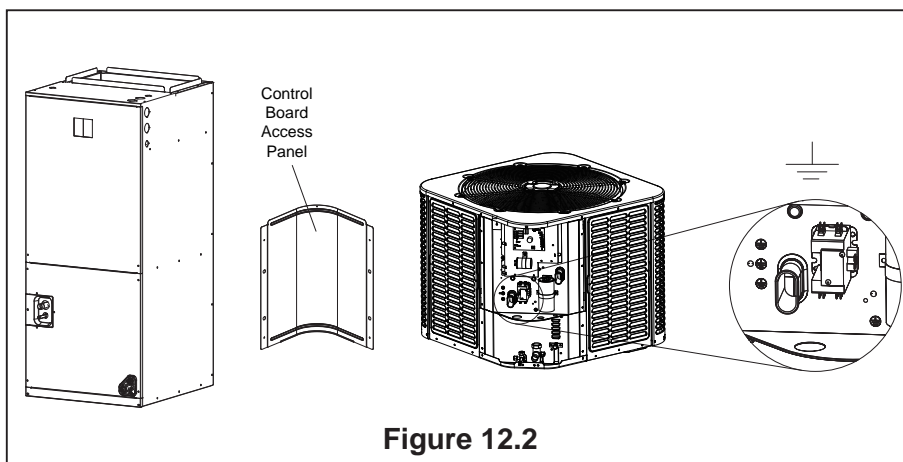


Figure 12.2

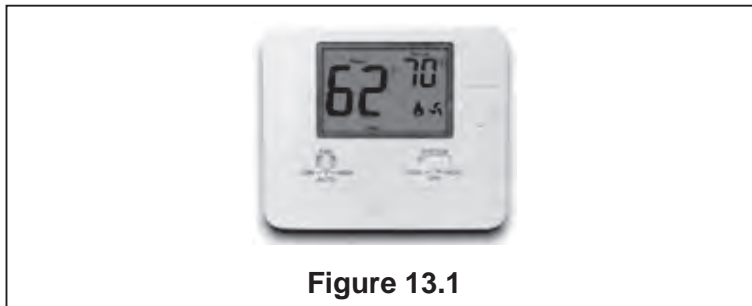
**Table 12.1 Wire gauge of high voltage system**

Type (Btu/ hour)			18K	24K	30K	36K	42K	48K	60K
Power	Phase	Single							
	Voltage/frequency	208/230VAC, 60 Hz							
Wire gauge	Indoor unit power cord	Line quantity	3	3	3	3	3	3	3
		Wire diameter (AWG)	16	16	16	16	16	16	16
	Outdoor unit power cord	Line quantity	3	3	3	3	3	3	3
		Wire diameter (AWG)	14	12	12	10	10	10	10

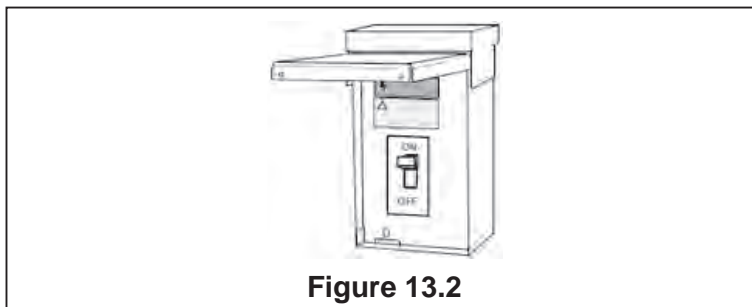
## 13. Start

### 13.1 System Startup

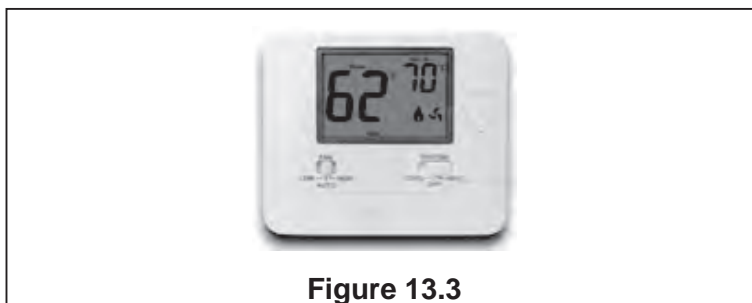
1. Make sure that Step 7, 8, 9, 10, 11 and 12 have been completed.
2. Set the system thermostat to off.



3. Turn on the disconnect switch and apply power to indoor unit and outdoor unit.



4. Set the system thermostat to ON.



# 14. System Refrigerant Charging Method

## 14.1 Refrigerant Charging: Weigh-In Method

Use weigh-in method the initial installation, or anytime a system charge is being replaced. Weigh-in method can also be used when power is not available to the equipment site or operating conditions (indoor/outdoor temperatures) are not in range to verify with the subcooling charging method.



The factory charge in the outdoor unit is sufficient for 4.6m(15ft) of standard size interconnecting liquid line. Additional 50g/m (0.54 oz/ft) refrigerant is needed when length of line-set is more than 4.6m(15ft).

### New Installations — Calculating additional charge for lineset greater than 4.6m(15ft).

1. Total length of line (ft) = \_\_\_\_\_(a)
  2. Standard line setup (ft) = 4.6m(15ft) (b)
  3. (a) minus (b) = \_\_\_\_\_ (c)
  4. Refrigerant multiplier = 50g/m (0.54 oz/ft) (d)
  5. Additional refrigerant quantity (c\*d) = \_\_\_\_\_(e)\*
- \* If the line set is less than 4.6m(15ft) , e = 0

### Sealed-System Repairs — Calculating total system charge.

1. Total length of line (ft) = \_\_\_\_\_(a)
  2. Standard line setup (ft) = 4.6m(15ft) (b)
  3. (a) minus (b) = \_\_\_\_\_ (c)
  4. Refrigerant multiplier = 50g/m (0.54 oz/ft) (d)
  5. Additional refrigerant quantity (c\*d) = \_\_\_\_\_(e)\*
  6. Factory filling quantity (nameplate) = \_\_\_\_\_(f)
  7. Total system charge (e + f) = \_\_\_\_\_
- \* If the line set is less than 4.6m(15ft) , e = 0

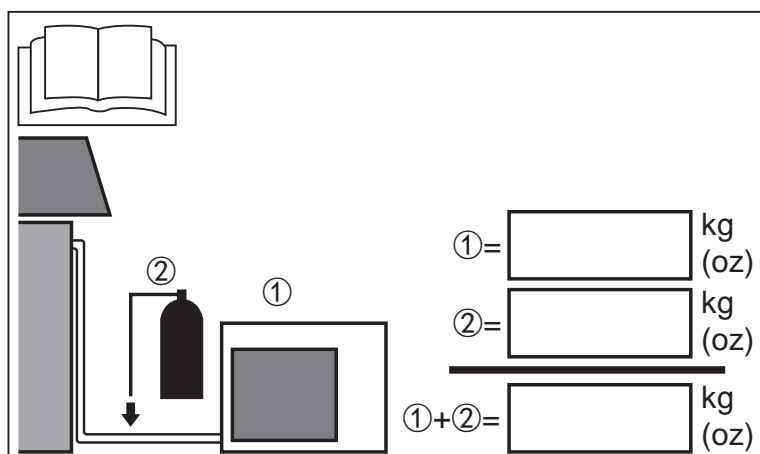


The only mode approved for verifying system charging is in " cooling mode".

You can refer to the above formula for calculation, or you can choose the appropriate refrigerant addition according to the piping length.

**Table 14.1 Additional Refrigerant Guidelines**

Piping length (ft)/(m)	Additional charge (oz)/(kg)
15/(4.6)	0
75 / (22.9)	32.4/(0.92)
100 / (30.5)	45.9/(1.30)
131 / (40.0)	62.1/(1.76)
147 / (44.8)	71.3/(2.02)



- ① REFRIGERANT CHARGE of the precharged part of the appliance
- ② REFRIGERANT CHARGE added during installation

## 14.2 Charging and Refrigerant Adjustment in Cooling Mode

### Check the outdoor ambient temperature

Check the ambient temperature. Subcooling method (cooling mode) is only for outdoor temperature between 68°F and 113°F, and indoor temperature between 68°F and 89°F. For temperature out of the range, use the weigh-in method mentioned above.

### Subcooling Method in Cooling for TXV Match-Ups

Calculate subcooling value in Cooling for TXV Match-Ups. Calculate subcooling value with measured liquid line temperature and pressure according to Table 14.2. If calculated subcooling value is lower than the design subcooling value of Table 14.4, refrigerant should be added. If calculated subcooling value is higher than the value of Table 14.4, refrigerant should be recovered.

### Superheat Method in Cooling for Piston Match-Ups

Calculate superheat value in Cooling for Piston Match-Ups. Calculate superheat value with measured vapor line temperature and pressure according to Table 14.3. If calculated superheat value is lower than the design superheat value of Table 14.5, refrigerant should be recovered. If calculated superheat value is higher than the value of Table 14.5, refrigerant should be added.

**Table 14.2**

Liquid Line Temperature (°F)	Subcooling Value (°F)							
	6	7	8	9	10	11	12	13
	Liquid Gauge Pressure (PSI)							
55	164	167	170	172	175	178	181	184
60	178	181	184	187	191	194	197	200
65	194	197	200	203	206	210	213	217
70	210	213	217	220	223	227	230	234
75	227	230	234	238	241	245	249	252
80	245	249	252	256	260	264	268	272
85	264	268	272	276	280	284	288	292
90	284	288	292	297	301	305	309	314
95	305	309	314	318	323	327	332	336
100	327	332	336	341	346	351	355	360
105	351	355	360	365	370	375	380	385
110	375	380	385	390	396	401	406	412
115	401	406	412	417	422	428	433	439
120	428	433	439	445	450	456	462	468
125	456	462	468	474	480	486	492	498

**Table 14.3**

Suction Temp (°F)	Superheat Value (°F)								
	6	8	10	12	14	16	18	20	22
	Suction Gauge Pressure (PSI)								
40	95	91	87	84	80	77	74	70	67
42	99	95	91	87	84	80	77	74	70
44	103	99	95	91	87	84	80	77	74
46	107	103	99	95	91	87	84	80	77
48	111	107	103	99	95	91	87	84	80
50	116	111	107	103	99	95	91	87	84
52	120	116	111	107	103	99	95	91	87
54	125	120	116	111	107	103	99	95	91
56	129	125	120	116	111	107	103	99	95
58	134	129	125	120	116	111	107	103	99
60	139	134	129	125	120	116	111	107	103
62	144	139	134	129	125	120	116	111	107
64	149	144	139	134	129	125	120	116	111
66	155	149	144	139	134	129	125	120	116
68	160	155	149	144	139	134	129	125	120
70	166	160	155	149	144	139	134	129	125
72	171	166	160	155	149	144	139	134	129

**Table 14.4**

Subcooling (°F)		Ambient Temperature (°F)				
		68~77	77~86	86~95	95~104	104~113
Model	18K	10±2	10±2	9±2	8±2	6±2
	24K	12±2	12±2	11±2	10±2	8±2
	30K	9±2	9±2	8±2	7±2	5±2
	36K	12±2	12±2	11±2	10±2	8±2
	42K	12±2	12±2	11±2	10±2	8±2
	48K	12±2	12±2	11±2	10±2	8±2
	60K	12±2	12±2	11±2	10±2	8±2

**Table 14.5**

Outdoor DB (°F)	Indoor DB/WB (°F)				
	90/75	85/71	80/67	75/63	70/58
110	8±2	7±2	5±2	5±2	5±2
100	9±2	8±2	6±2	5±2	5±2
90	11±2	9±2	8±2	6±2	5±2
80	12±2	10±2	8±2	7±2	5±2
70	12±2	10±2	8±2	7±2	5±2
60	14±2	11±2	9±2	7±2	5±2

# 15. System Operation and Troubleshooting

## 15.1 Control Logic Description

- The system is using universal 24V control.

## 15.2 Sensors and valves

- T3- Outdoor unit coil temperature only for HP units(Table 15.2)
- T4- Ambient temperature only for HP units(Table 15.2)
- T5- Compressor discharge temperature only for HP units(Table 15.3)
- TH- Compressor suction temperature only for HP units(Table 15.2)
- HP- High pressure switch
- LP- Low pressure switch
- DT- Compressor discharge temperature switch only for AC units

## 15.3 Defrost Description

- Automatic Defrost Control Function.

The outdoor unit will enter defrost mode automatically according to T3 temperature.

- Fixed Time Defrost.

When the dip switch SW2-2 is set to ON, the Fixed Time Defrost Mode is activated, and the SW2-3 offers different fixed time options. SW2-2 and SW2-3 are set to OFF by default.

- Manual Defrost.

The outdoor unit will enter defrost mode automatically When the dip switch SW2-1 is set to ON.

## 15.4 Compressor Crankshaft Heater Control Function

The outdoor unit will Automatically turn on and off the crankshaft heating belt function according to the T5 temperature.

## 15.5 Operation of Reversing Valve

- ▶ The reversing valve is energized in heating mode and de-energized in cooling mode.



During the heating signal of the first operation, the unit will run in the cooling state for about 1 minute, accumulating pressure for reversing the reversing valve.

## 15.6 Defensive Function

- Temperature protection of outdoor coil in cooling mode (T3 only for HP units)
  1. If  $T3 > \text{Maximum set temperature}$ , the system stops for protection.
  2. If  $T3 < \text{the set recovery temperature value}$ , the system restarts.

**Note:** Please consult the supplier for maximum temperature and recovery temperature.
- Compressor discharge temperature protection (T5 for HP units, DT for AC units)
  1. In cooling or heating mode, if the temperature is higher than the set maximum value, the system will stop for protection.
  2. In cooling or heating mode, if the temperature is lower than the set recovery temperature, the system will restart.

**Note:** Please consult the supplier for maximum temperature and recovery temperature.

Please consult the supplier for specific values.

- Temperature protection of outdoor coil in cooling mode (TH only for HP units)

1. If TH > Maximum set temperature, the system stops for protection.
2. If TH < the set recovery temperature value, the system restarts.

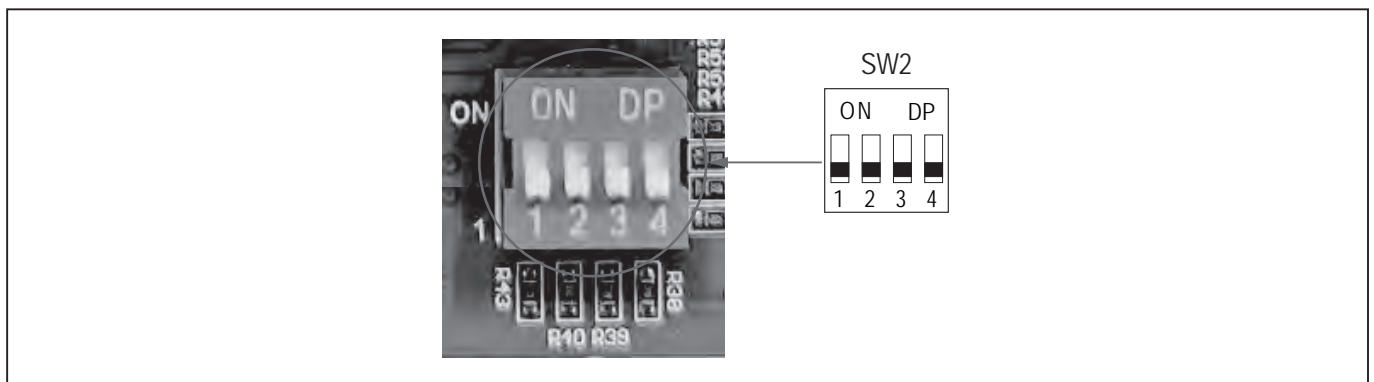
**Note 1:** Please consult the supplier for maximum temperature and recovery temperature.

**Note 2:** Please match with indoor unit that have Anti-Freezing Function. If AC outdoor units match with an indoor unit which does not have the anti-freezing protection, the anti-freezing protection KIT is recommended.

## 15.7 SW1 DIP SWITCH Description

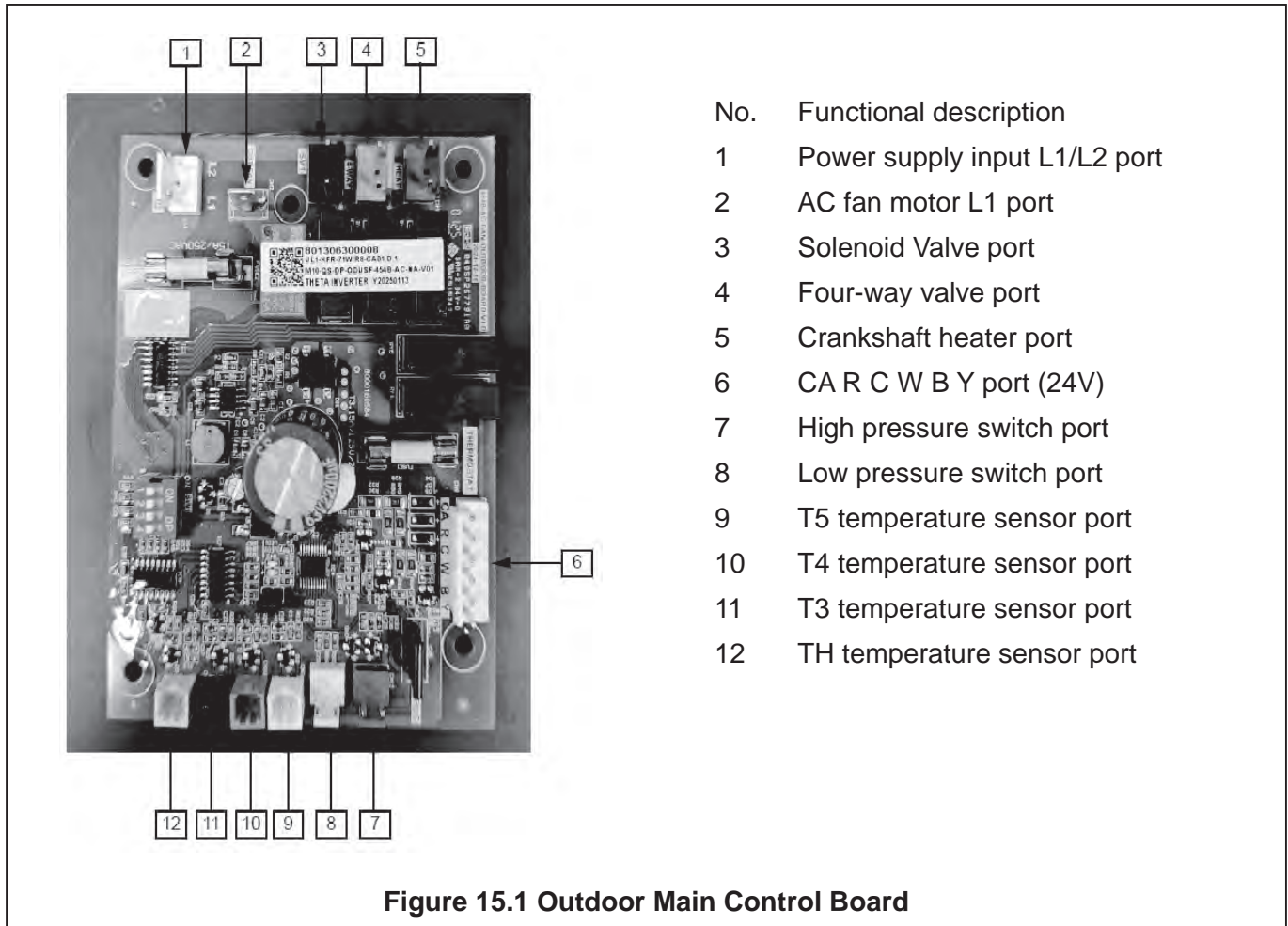
- The dip switch SW2-1 & SW2-2 & SW2-3 offers different defrost mode options, SW2-4 offers general mode or high-vertical mode options.

Dial	SW2-1	SW2-2	SW2-3	SW2-4
ON	Manual defrost mode	Fixed time defrost mode	30 Min	High-vertical mode
OFF	- (Default)	Automatic defrost mode(Default)	60 Min(Default)	General mode(Default)



## 15.8 Overview of Main Control Board

### Outdoor Main Control Board



## 15.9 Troubleshooting of Fault Codes



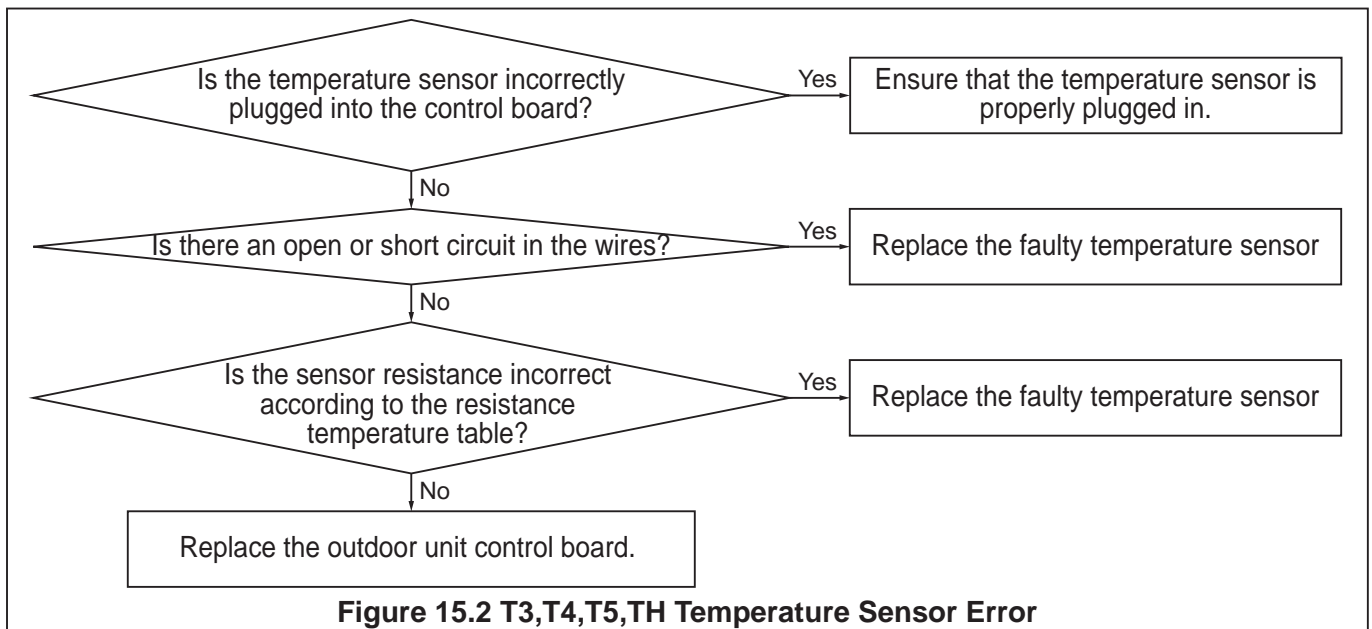
### Warning: Dangerous voltage

- When measuring the resistance, make sure that the power of the unit is turned off and wait for 3 minutes at least before measuring.

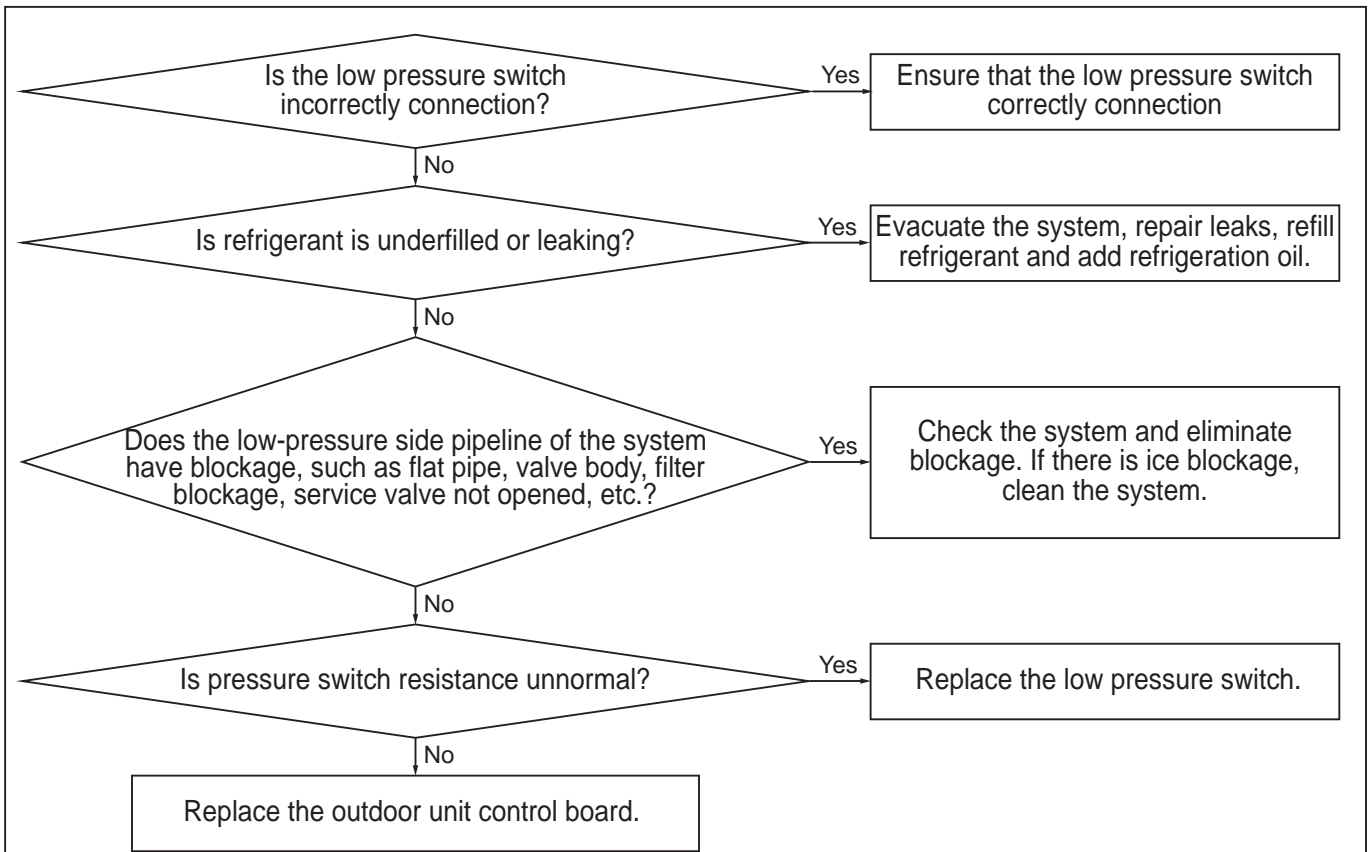
- Only for HP units, the control board displays fault codes. For AC units, No control board.
- When a fault occurs, the LED light will flash. The flashing LED light flashes with the fault category number as the number of times, then stops for 4 s, and keeps cycling until the fault state is cleared.

**Table 15.1 LED Display Fault Code**

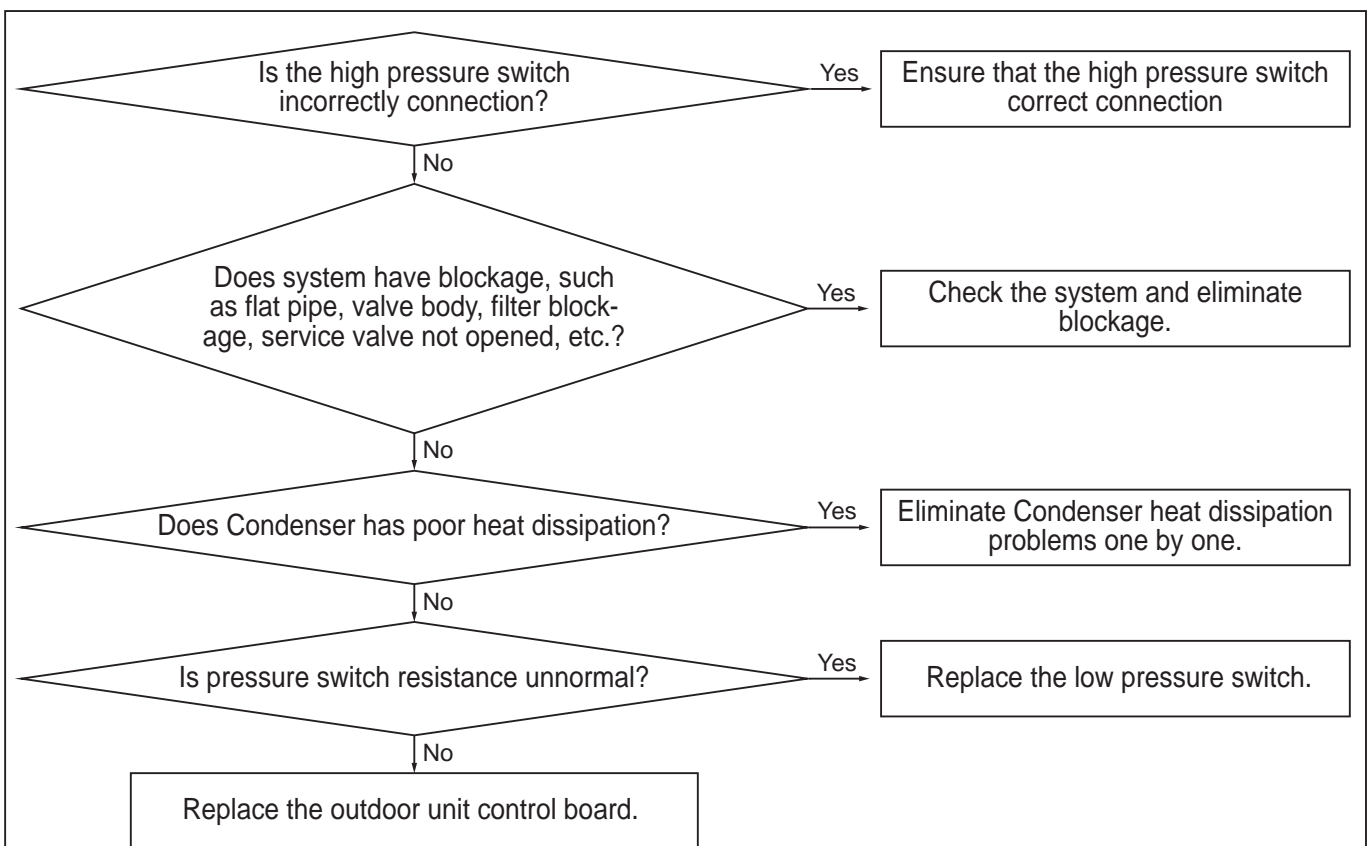
	LED Status	System status
Model	Green light always on Red light always off	Standby or Runing Mode
	Green light always off Red light always off	Off Mode
System warning	Green light 1 Flash/Cycle Red light always off	Low Pressure Protection
	Green light 2 Flash/Cycle Red light always off	High Pressure Protection
	Green light 3 Flash/Cycle Red light always off	T5 High Compressor Discharge Temperature Protection
	Green light 4 Flash/Cycle Red light always off	TH Anti-freezed Protection
	Green light 5 Flash/Cycle Red light always off	T4 Ambient Temperature Protection
	Green light 6 Flash/Cycle Red light always off	T3 High Temperature Protection
	Green light always off Red light 1 Flash/Cycle	T3 Sensor Error
	Green light always off Red light 2 Flash/Cycle	T4 Sensor Error
	Green light always off Red light 3 Flash/Cycle	T5 Sensor Error
	Green light always off Red light 4 Flash/Cycle	TH Sensor Error
System lock	Green light always off Red light 5 Flash/Cycle	Low Pressure Lock, 6 times Low Pressure Protection within 60 minutes
	Green light always off Red light 6 Flash/Cycle	High Discharge Temp. Lock, 3 times High Compressor Discharge Temp. Protection within 60 minutes
	Green light always off Red light 7 Flash/Cycle	Anti-freezed Lock, 8 times TH Anti-freezed Protection within 200 minutes



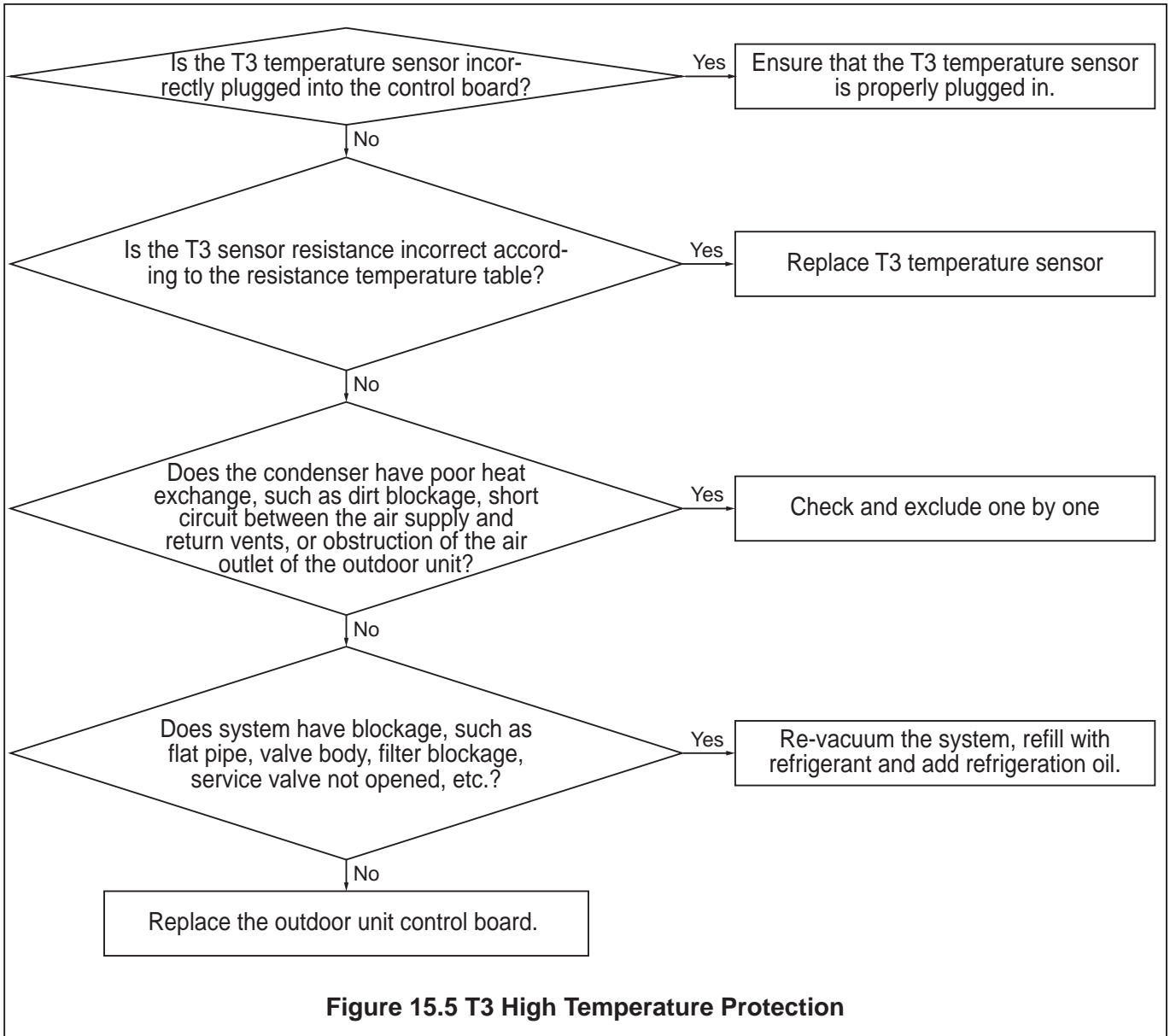
**Figure 15.2 T3,T4,T5,TH Temperature Sensor Error**

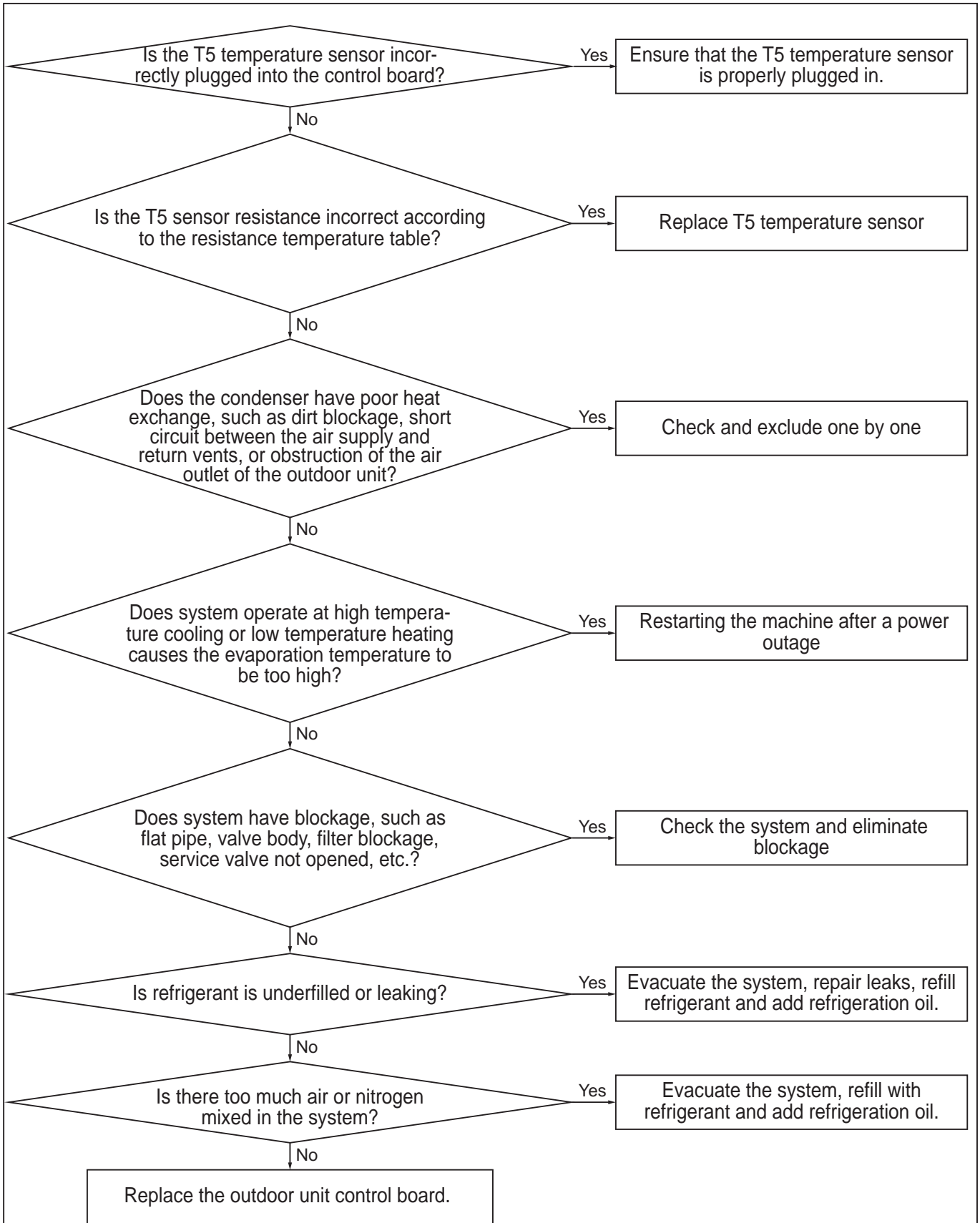


**Figure 15.3 Low Pressure Protection**

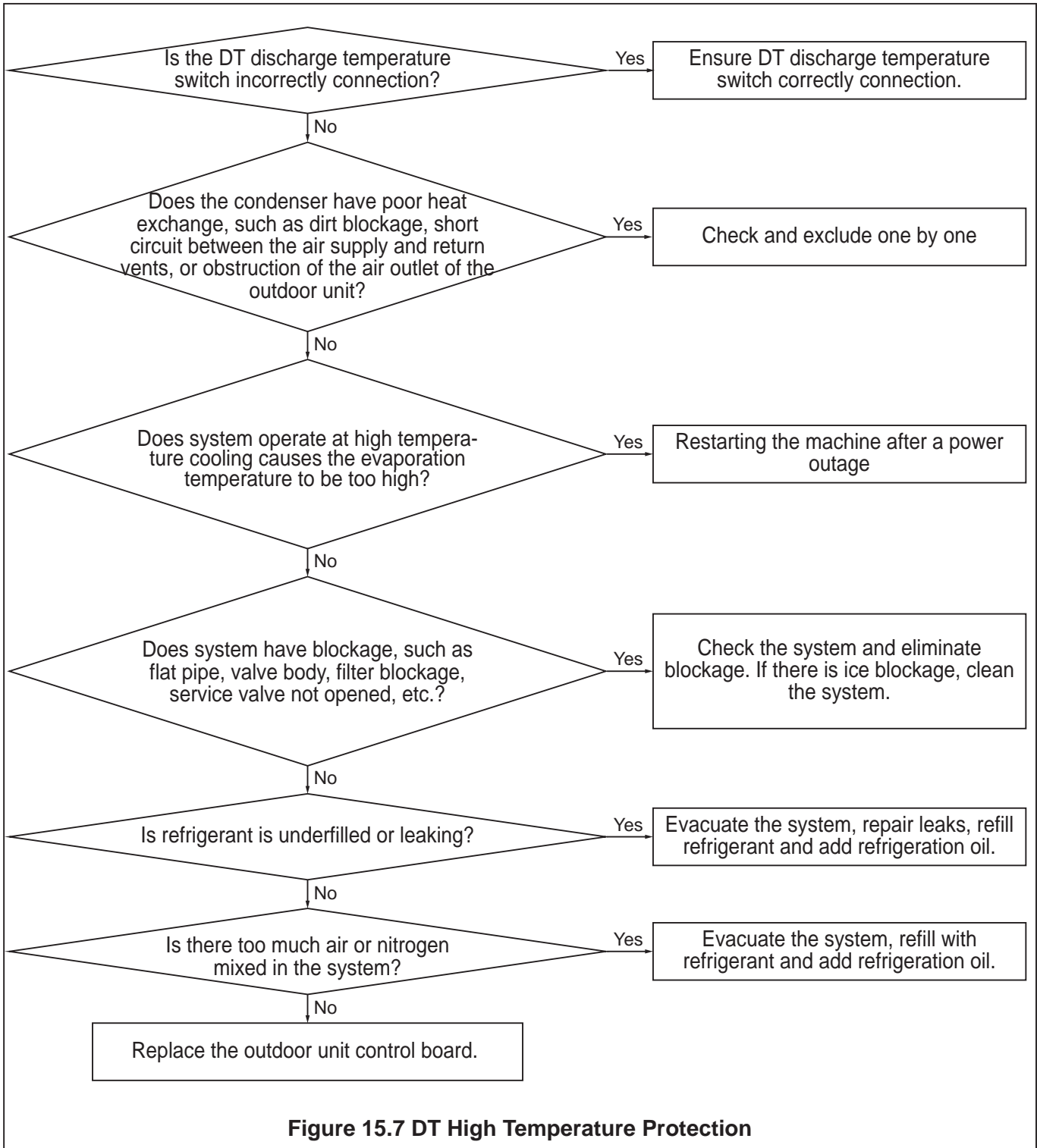


**Figure 15.4 High Pressure Protection**





**Figure 15.6 T5 High Temperature Protection**



**Figure 15.7 DT High Temperature Protection**

## 15.10 Temperature-Resistance Relationship Table (For Sensors)

Table 15.2 for T3, T4, TH

Temperature F	Temperature C	Electric resistance kΩ	Volt DC	Temperature F	Temperature C	Electric resistance kΩ	Volt DC
-5	-20.6	33.367	0.57	90	32.2	3.865	2.63
0	-17.8	29.227	0.64	95	35.0	3.508	2.75
5	-15.0	25.657	0.72	100	37.8	3.187	2.87
10	-12.2	22.595	0.80	105	40.6	2.900	2.99
15	-9.4	19.942	0.89	110	43.3	2.652	3.09
20	-6.7	17.697	0.98	115	46.1	2.421	3.20
25	-3.9	15.673	1.08	120	48.9	2.214	3.30
30	-1.1	13.917	1.18	125	51.7	2.025	3.40
40	4.4	11.060	1.40	130	54.4	1.861	3.49
45	7.2	9.867	1.52	135	57.2	1.706	3.58
50	10.0	8.823	1.64	140	60.0	1.567	3.66
55	12.8	7.884	1.76	145	62.8	1.442	3.74
60	15.6	7.101	1.89	150	65.6	1.327	3.82
65	18.3	6.409	2.01	155	68.3	1.226	3.89
70	21.1	5.767	2.14	160	71.1	1.132	3.96
75	23.9	5.150	2.28	165	73.9	1.046	4.02
80	26.7	4.700	2.39	170	76.7	0.967	4.08
85	29.4	4.266	2.51				

## 15.11 Temperature-Resistance Relationship Table (for T5 sensor)

Table 15.3 for T5

Temperature F	Temperature C	Electric resistance kΩ	Volt DC	Temperature F	Temperature C	Electric resistance kΩ	Volt DC
-5	-20.6	496.38	0.08	140	60.0	12.348	1.97
0	-17.8	422.97	0.09	145	62.8	11.164	2.10
5	-15.0	361.35	0.11	150	65.6	10.106	2.22
10	-12.2	309.74	0.13	155	68.3	9.193	2.34
15	-9.4	266.152	0.15	160	71.1	8.344	2.46
20	-6.7	230.462	0.17	165	73.9	7.585	2.58
25	-3.9	198.968	0.19	170	76.7	6.904	2.69
30	-1.1	172.231	0.22	175	79.4	6.313	2.80
35	1.7	149.467	0.26	180	82.2	5.761	2.92
40	4.4	130.642	0.29	185	85.0	5.263	3.02
45	7.2	113.87	0.33	190	87.8	4.815	3.13
50	10.0	99.456	0.37	195	90.6	4.410	3.23
55	12.8	87.095	0.42	200	93.3	4.057	3.33
60	15.6	76.425	0.48	205	96.1	3.724	3.42
65	18.3	67.501	0.53	210	98.9	3.423	3.51
70	21.1	59.457	0.60	215	101.7	3.149	3.60
75	23.9	52.489	0.67	220	104.4	2.910	3.67
80	26.7	46.429	0.74	225	107.2	2.689	3.75
85	29.4	41.322	0.82	230	110	2.476	3.82
90	32.2	36.682	0.90	235	112.8	2.288	3.89
95	35.0	32.619	0.99	240	115.6	2.117	3.96
100	37.8	29.068	1.09	245	118.3	1.965	4.02
105	40.6	25.948	1.19	250	121.1	1.821	4.08
110	43.3	23.291	1.29	255	123.9	1.690	4.13
115	46.1	20.855	1.39	260	126.7	1.569	4.19
120	48.9	18.708	1.51	265	129.4	1.462	4.23
125	51.7	16.809	1.62	270	132.2	1.360	4.28
130	54.4	15.184	1.73	275	135.0	1.266	4.32
135	57.2	13.682	1.85	280	137.8	1.180	4.36

# 16. Wiring Diagram

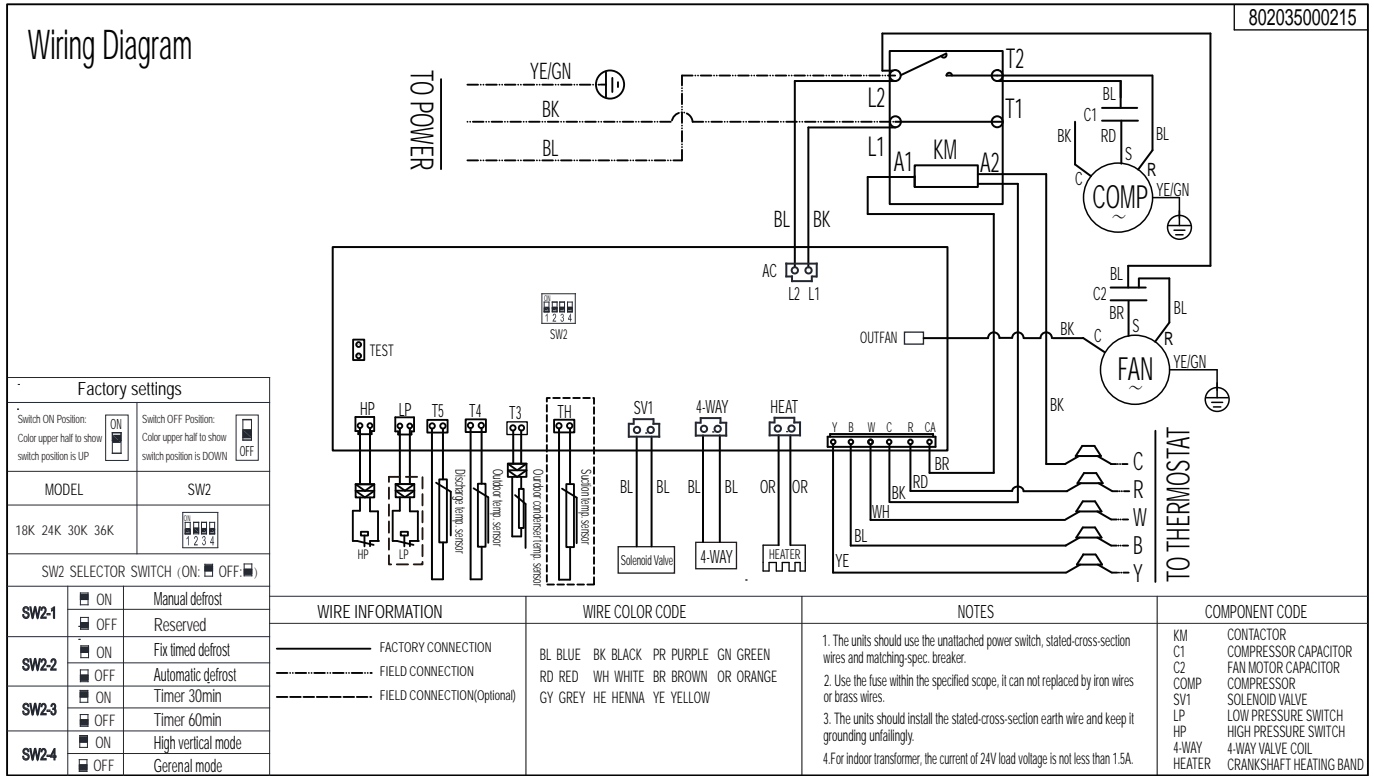


Figure 16.1 HP units

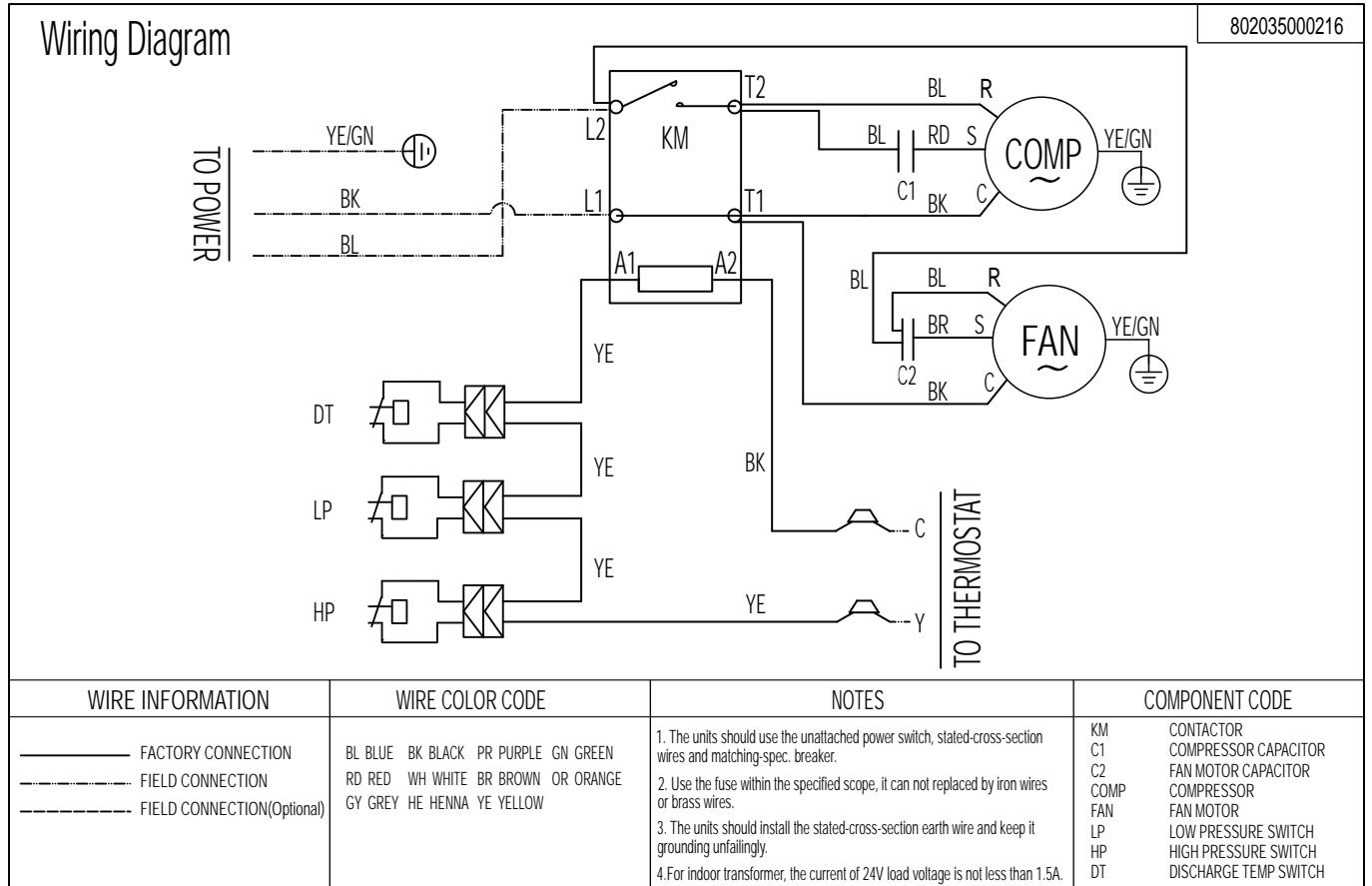


Figure 16.2 AC units

# 17. Cleaning and Maintenance

## 17.1 Cleaning Precautions



### Warning:

- Any maintenance and cleaning of outdoor units can only be carried out by qualified maintenance personnel.
- Any unit maintenance can only be carried out by qualified maintenance personnel.



### Caution: Electric shock

- Be sure to turn off the unit and disconnect the power supply before cleaning or maintenance.



### Note:

- Do not use chemicals or chemically treated cloth to clean the unit.
- Do not use benzene, paint thinner, polishing powder or other solvents to clean this unit.







### Be careful:

- When removing the filter, do not touch the metal parts in the unit. Sharp metal edges can cut you.

## 17.2 Pre-Season Inspection and Maintenance

At the start of each heating or cooling season, do the following:

	Turn off the unit and disconnect the power supply.
 	Check for damaged wires, check for leaks.
	Make sure that all air inlets and outlets are not blocked.

**Table 17.1**

## 17.3 Sheet Metal Parts Fastening



### Note:

- Do not use a torque greater than 1.1lb\*ft(1.5N\*m) to drive the screws, otherwise the screws may slip and the sheet metal may not be completely tightened.



802034000093 V1

Design, material, performance specifications and components  
subject to change without notice.